



# PRODUCT CATALOGUE

**THE POWER OF ROOFS**



# MODULAR SERIES

IZI<sup>ROOF</sup>



IZI<sup>LOOK</sup>



ZET<sup>ROOF</sup>

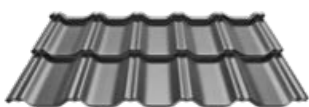

ZET<sup>LOOK</sup>

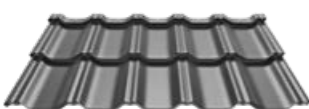

# PANEL SERIES

FIT

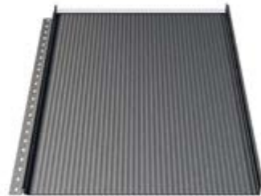

ZIPP

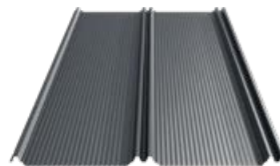

LAMBDA 2.0



# COMPACT SERIES

IZI 2.0



FINN 2.0



ALFA 2.0



HETA 2.0



GAMMA 2.0



STIGMA 2.0



BAVARIA<sup>ROOF</sup> 2.0

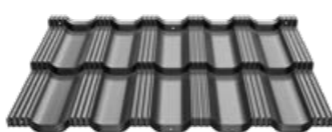

# CLASSIC SERIES

FINN



ALFA



GAMMA



STIGMA



BAVARIA<sup>ROOF</sup>

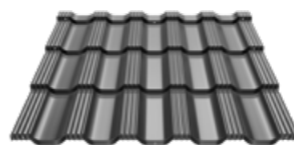

# RETRO SERIES

FINN<sup>RETRO</sup>

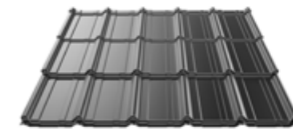

ALFA<sup>RETRO</sup>



GAMMA<sup>RETRO</sup>

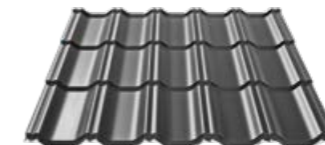

STIGMA<sup>RETRO</sup>

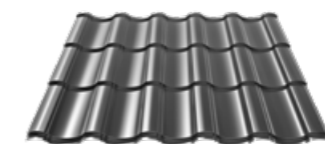

BAVARIA<sup>ROOF</sup> RETRO

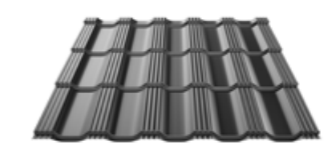

# SOLROOF

FIT<sup>VOLT</sup>



INGURI



SINUS



BP2 - THE POWER OF ROOFS  
Scan the code and learn more.



1.

**About us**

- 8. Welcome to BP2 world
- 9. Why us?
- 10. History
- 11. Production plants
- 14. eProfil
- 14. Laboratory
- 15. Academy of Masters
- 17. Master Roofer Waldemar Piela

2.

**SOLROOF**

- 20. What is SOLROOF?
- 22. Technical information

3.

**MODULAR SERIES**

- 28. IZI ROOF
- 30. IZI LOOK
- 32. ZET ROOF
- 34. ZET LOOK
- 36. Colours
- 37. Feedstock

4.

**PANEL SERIES**

- 42. FIT
- 44. ZIPP
- 46. LAMBDA 2.0

5.

**COMPACT SERIES**

- 58. IZI 2.0
- 60. FINN 2.0
- 61. ALFA 2.0
- 62. HETA 2.0
- 63. GAMMA 2.0
- 64. STIGMA 2.0
- 65. BAVARIA Roof 2.0

6.

**CLASSIC SERIES**

- 70. FINN
- 72. ALFA
- 73. GAMMA
- 74. STIGMA
- 75. BAVARIA Roof

7.

**RETRO SERIES**

- 80. FINN RETRO
- 81. ALFA RETRO
- 82. GAMMA RETRO
- 84. STIGMA RETRO
- 85. BAVARIA Roof RETRO

8.

**Steel gutter system INGURI**

- 88. Technical information
- 89. Description of elements
- 90. Advantages of INGURI
- 94. Colours
- 95. Feedstock

9.

**Flashings & accesories**

- 98. New flashings
- 100. Flashings
- 104. Accesories

10.

**Trapezoidal sheets**

- 110. SINUS
- 112. T7, T14
- 113. T18, T18 ECO
- 114. T35, T35 ECO
- 115. T50, T55
- 116. T60, T80
- 117. T130, T135-930
- 118. T135-950, T153
- 119. T160, T200

11.

**Liner tray & PROSYSTHERM**

- 122. Liner tray
- 123. Installation
- 124. PROSYSTHERM 90 min fire rated wall

12.

**Sandwich panels**

- 128. Sandwich panels CORE PIR
- 138. Sandwich panels CORE WOOL

13.

**Cladding cassettes & panels**

- 150. SKRIN cladding cassettes
- 151. Technical specifications
- 160. LINEA cladding panels
- 161. Colours and perforation

14.

**Steel Service Centre**

- 164. Steel service centre
- 165. Range of offerings
- 166. Cutting and recoiling services
- 167. Protection and packaging
- 168. Perforation of sheets

15.

**Technical information**

- 172. ALUZINC and ZINC coatings
- 173. Coated sheets
- 174. Coating descriptions
- 176. Coating properties
- 177. Coating availability
- 178. Anti-condensation coating
- 180. Colours

16.

**Contact us**

- 184. Helpful links
- 186. Contact us





# 1.

## About us

8. Welcome to BP2 world

9. Why us?

10. History

11. Production plants

14. eProfil

14. Laboratory

15. Academy of Masters

17. Master Roofer Waldemar Piela

# Welcome to BP2 world

BP2 has been a valued manufacturer of complete solutions for residential and industrial construction since 1995. We also offer our services as part of the Steel Service Centre.

We are the creators of the SOLROOF brand and products – integrated photovoltaic roof. BP2 has five production plants in Poland (Cracow, Dąbrowa Górnicza), Slovakia (Košice) and Romania (Cluj Napoca, Timisoara).



# Why us?

We believe in what we do and we are true to our values.

We are discerned with a solid bond with customers, which is based on respect and trust. In our company, every element of a great machine must fit together perfectly. Our company is built on four pillars that are strong as steel, guarantee stability and enable continuous development. These basic assumptions guarantee high efficiency and quality, with the resultant sense of solidarity and confidence in cooperation. Therefore, you can focus on achieving your goal.



### PEOPLE

The whole company and the positive relations are created by people. Everybody in the BP2 team has the respective opportunities for comfort work and the best tools for its performance.

For this purpose, we constantly improve our management processes. Our decision-making and information flow is transparent.

Similarly to a pack of wolves, we work as a team to achieve the success.

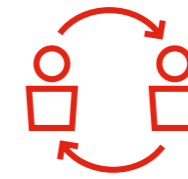

### RELATIONSHIPS

At BP2, we have been building professional relationships with our customers, suppliers and affiliates for many years.

We are focused on transparent communication and dialogue. We care about our customers by offering them modern cooperation tools and marketing software support.

Our company flexibly adapts to the customer needs, because nature of the market is ever-changing.



### TECHNOLOGY

We focus on innovative solutions and modern technologies ensuring constant optimization of the production, expansion of our offer, quality improvement of our products and services, while simultaneously maintaining the sustainable development and safety of employees.

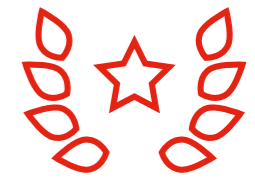

### QUALITY

Quality is our priority. In all BP2 production plants the complete control system has been implemented for all the processes and products, with the purpose of the highest quality in action. DVS ZERT GmbH certification unit, located in Dusseldorf, provides constant supervision over our quality-oriented internal promotion activities. Our constant care for the quality of products is proved by the Certificate issued and renewed each year. This Certificate confirms the perfect operation of the Production Control System in the plant.



### Housing

BP2 manufactures modular and compact sheet metal roofing tiles and corresponding products in the form of cut-to-size sheets. We can also boast three innovative models of roof panels, as well as a wide range of trapezoidal and corrugated sheets. Our range is complemented by gutter systems and dedicated flashings and roof accessories.



### Industrial building

Our offer includes a wide range of products intended for the implementation of investment tasks, i.e. production halls, outbuildings or commercial and sports facilities. We offer comprehensive solutions for industrial construction, such as structural trapezoidal sheets and corrugated SINUS sheets, wall cladding and façade coffers. Our offer also includes sandwich panels with PIR, PUR and WOOL filling. Products dedicated to industrial construction are also available in perforated versions at the customer's request. The available solutions are of the highest quality that enable them to be used in even the most demanding industrial applications.



### Steel Service Centre

It was created for customers looking for materials with specific properties and degrees of processing. We ensure constant availability and a wide selection of steel grades, thicknesses and coatings recommended by BP2. We realize individual orders with any parameters. Sheet metal processing includes rewinding, longitudinal and transverse cutting as well as protection with protective foils. We make it possible to cut metal sheets into sheets or formats with dimensions indicated by the customer. We offer perforation of sheets with metallic and organic coatings. We also accept orders using entrusted material, ensuring optimal use thanks to high-quality production processes.

# History

**FIRST LINE 1999**  
We launch the first roofing production line and start creating our own products.

**IMPRO 2009**  
New directions of development led to the creation of the IMPRO brand, which belongs entirely to the BP2 capital group. The headquarters of the Romanian company looks almost identical to its prototype, i.e. BP2 in Cracow.

**AUTOMATION 2011**  
We believe in the power of technology, which not only ensures increased production, but also allows you to increase the comfort and safety of work. In 2011, we automated manufacturing processes in the logistics and production centre in Cracow.

**CLUJ NAPOCA 2016**  
We open a modern production hall in the Transylvanian Highlands in north-western Romania. Thus, we create new jobs for the inhabitants of Cluj Napoca.

**WOLF 2018**  
Choosing the image of a wolf for the BP2 signet ring. Wolves are herd animals whose lifestyle symbolizes the idea of teamwork that is close to our hearts

**IZI 2019**  
We introduce to our offer the original IZI flat modular tile, which is the latest trend in aesthetic and modern construction.

**COMPACT SERIES 2020**  
We introduce COMPACT SERIES sheet metal roof tiles to our offer, manufactured on the basis of classic solutions in the form of light, two-module sheets. We have also introduced ready-made mounting holes that facilitate the installation of metal roof tiles and eliminate the risk of making a technical error.

**EXPANSION OF IMPRO ACTIVITIES 2022**  
In 2022, we undertook many investment activities, including the expansion of the IMPRO production plant. We also established the Academy of Masters operating at one of the IMPRO production plants – for this purpose, a modern training centre was created, enabling the improvement of practical skills.

**1995 LET'S GET STARTED!**  
Initially focused on the Polish market. The headquarters of our company is in Cracow and it is here that the heart of production is located for the first few years.

**2007 LOGISTIC CENTRE**  
We are opening a modern logistics and production centre located in Cracow, thanks to which we diversify our product offer and introduce new, competitive solutions to the market.

**2009 INTO EUROPE**  
We create our own distribution network in Europe. Our permanent sales representatives operate in the Czech Republic, Slovakia, Lithuania, Hungary and Romania. In this way, we not only become important players on the European arena, but also have the opportunity to indicate new trends in roofing.

**2015 NEW PRODUCTION PLANT**  
We launch an innovative, automated production hall and expand the offer of structural sheets. From now on, our production plants are located not only in Małopolska, but also in the Silesian Voivodeship in Dąbrowa Górnicza.

**2017 ADAM MAŁYSZ AND THE ACADEMY OF MASTERS**  
Adam Małysz officially becomes the Ambassador of the BP2 brand! The best ski jumper among roofers, the best roofer among ski jumpers. In the same year, we also launched an original training program as part of mobile and stationary meetings of the ACADEMY OF MASTERS. Our trainings raise the standards of roofing knowledge and allow specialists to become even more competitive on the market.

**2018 INVESTMENTS**  
The former MARCEGAGLIA production plant in Romania was incorporated into the BP2 capital group. From now on, we start the production of sandwich panels in Romania.

**2021 MODERN TRAINING CENTRE**  
In order to provide the participants of the Academy of Masters with the best possible development opportunities, we have created a training room in our production plant in Dąbrowa Górnicza. This is a special place that we have filled with the equipment necessary to expand roofing skills, raising the knowledge and practice of specialists to a different level.

**2023 SOLROOF – INTEGRATED PHOTOVOLTAIC ROOF**  
In 2023, we launched our new brand and products SOLROOF, an integrated photovoltaic roof, which was developed in response to the growing demand for clean energy.

**2023 VSS**  
We open a modern logistics and production centre in Košice – the largest city in eastern Slovakia. From that point on we start the production of sandwich panels in Slovakia.

# Production plants

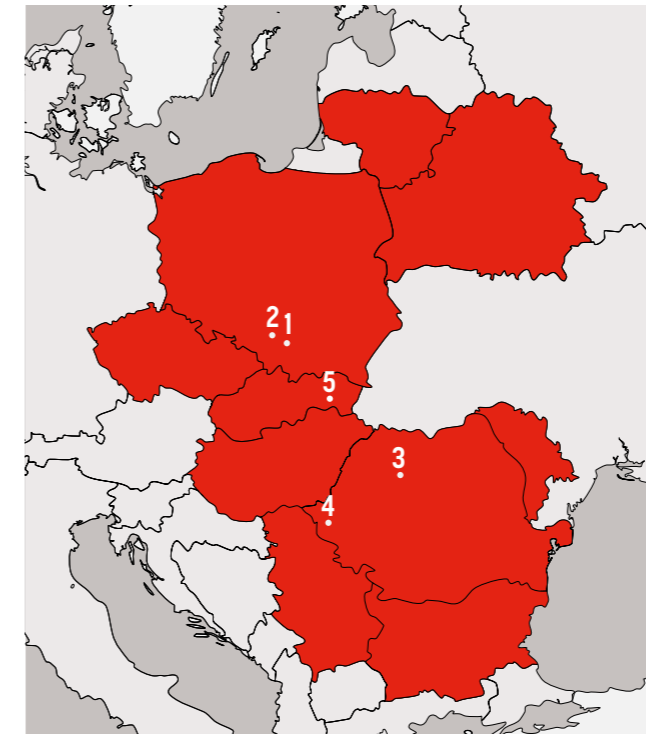
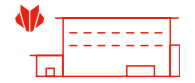

BP2 has 5 integrated production plants in Poland, Slovakia and Romania. The plants are connected logistically and systemically, creating a uniform structure of production plants of high product specialization.

## 1 Production plant in Kraków

It is one of the first production plants built by BP2. It was brought to life in 2007. Its modern appearance and interior design became the starting point for subsequent BP2 investments. A well-thought-out location, located at the A4 motorway, makes our plant an ideal logistics point. In the production plant, we focus on the production of products for housing construction.



## 2 Production plant in Dąbrowa Górnicza

The dynamic development has opened up new opportunities for us. In 2015, a production plant in Dąbrowa Górnicza was purchased. This part of the capital group quickly began to play an important role in the global production of BP2. There is also a BP2 training centre in Dąbrowa Górnicza, where, as part of the Academy of Masters – an original practical training program conducted by the Certified Roofing Master Waldemar Piela, we enable you to gradually optimize your work and improve your qualifications.



## 3 Production plant in Cluj-Napoca

Extensive investment plans led us to Romania, where in 2016 our next production plant was built. We took care of the details to maintain the consistency of our brand, which is why the plant in Cluj-Napoca is a faithful representation of the plant in Cracow. Fully functional and independent, it became the first foreign investment with a real impact on the increase in the production of the BP2 capital group, which is known under the IMPRO brand.



## 4 Production plant in Timisoara

It was purchased in 2018. The former MARCEGAGLIA production plant was incorporated into the BP2 capital group. After the modernization of the production lines, the processes were optimized to the standards developed by our brand, taking into account the care for high quality products, safety and sustainable development. Currently, the production plant in Timisoara produces products for industrial construction, such as sandwich panels and structural trapezoids.



## 5 Production plant in Košice

Due to our dynamic development, in 2022 we opened another production plant in Slovakia, located in the second largest city of our southern neighbours. The plant has an area of 21,000 m<sup>2</sup> and is adapted to the production of sandwich panels. A Steel Service Centre was also launched at the production plant.



# ePROFIL



The eProfile Internet platform is an extensive customer service system which is constantly being improved with new features. It allows almost unlimited control over the order placed. It allows you to check the stage of completion, locate the transported product on a map in real time and fully control the balance, payments and transaction history. eProfile also provides access to current price lists and promotions, as well as the ability to easily create a cost estimate for the end customer.

The roof optimiser module enables you to create a calculation of the required material according to the project in no time at all, thus reducing waste and unnecessary costs to a minimum. The program visualises the arrangement of sheets on the roof, helps to select the most cost-effective solution, generate a ready design and place an order. The eProfile service platform is a multifunctional tool for streamlining the order processing process and saving our customers' time."

# BP2 laboratory

Quality of the products in our offer is of great importance. Our focus is made on overall aesthetics and the extremely important technical aspects, both. We have established our own professional laboratories in Poland and Romania, where our products and materials are subject to demanding tests. As a result of this solution, we provide safe and weather-resistant products to our customers.

Quality control is carried out with the use of our knowledge and the innovative testing equipment. We rely on the professional team of specialists who investigate the processes at time of coating and processing the steel from our offer. In laboratory tests, we are able to faithfully simulate conditions that reflect several decades of the exposure to various atmospheric factors.



**BP2 - Laboratory**  
Scan code and learn more!

# Academy of Masters



ACADEMY OF MASTERS

The BP2 Academy of Masters is a genuine practical training program, carried out by our Certified Roofing Master, Mr. Waldemar Piela. Your professional curiosity will be satisfied with our trainings; as a result, you will gradually optimize your work and improve your qualifications. With it, you can become a competitive professional on the market of roofing services.

We have transformed our more than 25 years of experience and our market impact into the education of the best roofers. We know that the Academy of Masters is a project that has helped many people. Since 2020, we have trained over 830 roofers, presenting them with the latest trends.

We are happy to share our knowledge. At the same time, we listen to your needs. The Academy of Masters training room is a modern, fully adapted and equipped space with the latest solutions for the product, and it is a place where theory and practice meet in the pursuit of perfection.





# Mobilna Akademia Mistrzów BP2

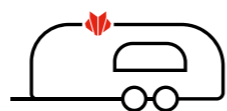

The construction industry is developing dynamically, which is why it is full of challenges and requires keeping up with trends. Thanks to our BP2 Mobile Academy of Masters, you can become a highly specialized roofer. With knowledge of innovative technological solutions, you will be able to implement the projects of the most demanding investors!

BP2 Mobile Academy of Masters means the experience exchange platform in the roofing industry. We have been on the road for you since 2017, providing trainings and inspirations. In 2022, we carried our assembly trainings for over 3,600 roofers with the use of 340 sheets of FIT and ZIPP roof panels. We travelled over 22,500 km, all of this to meet you.

We pay special attention not only to new knowledge, but also to integration, familiarising with each other and discussing ideas in the industry. Your opinions and observations are extremely important to us. The BP2 brand is built by the entire community, which includes i.e. contractors (roofers).

In order to complete our meetings, additionally to the support of the expert BP2 training team, we offer the iconic refreshments that you liked so much. In 2022, in our old-school Airstream trailer, we have prepared 5,270 juicy burgers and 18,000 refreshing drinks for you!



 **Mobile Academy of Masters BP2**  
Scan the code and watch a video of our tour.

# Master Roofer - Waldemar Piela



## TECHNICAL SUPPORT

Unfortunately, many manufacturers end their support at the stage of the sales or delivery of materials, unlikely to our approach! We offer you a comprehensive support at time of work with our products, both in terms of general advices and solving any problems.

Waldemar Piela has over 40 years of experience in the roofing industry. As a Master Roofer, he advises BP2 in the technical aspects and supports the development of the industry by educating the community of professionals. Among others, our Master is a member of the examination committee of the Mazovian Chamber of Crafts, and thanks to his commitment as its president, the Polish Roofers Association gained the status of an ordinary member in the World Roofing Federation (Internationale Föderation Des Dachdeckerhandwerks, IFD).

Waldemar Piela is an authority in the roofing industry thanks to his extensive skills and passion. He shares his knowledge during the trainings carried out as part of the ACADEMY OF MASTERS and MASTER ROOFER programs.

**CERTIFIED MASTER ROOFER**  
**WALDEMAR PIELA**

*W. Piela*





# 2.

## **Integrated photovoltaic roof SOLROOF**

20. What is SOLROOF?

22. Technical information

**FIT VOLT**



## What is SOLROOF?

SOLROOF is an innovative system that was created in response to the growing demand for clean energy. It is the only complete photovoltaic system on the market that is fully integrated into the steel roofing. Proprietary solutions allow for unique aesthetics of the roof and the use of various forms and shapes, which is not possible to achieve in the case of a conventional photovoltaic installation. The combination of FIT sheet metal panels and integrated FIT VOLT photovoltaic panels creates a coherent, harmonious coverage surface.

The SOLROOF integrated photovoltaic roof represents new quality that, as the first on the market, offers architects unlimited design possibilities, roofers easy and quick installation and the investor a unique visual effect, efficiency and safety of use. We achieve this by using one product, one assembly, one warranty, and one service.

# 2IN1 STEEL PHOTOVOLTAIC ROOF

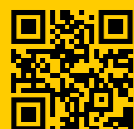

Scan code or find out more at [www.solroof.eu](http://www.solroof.eu)

**THE POWER OF ROOFS**





# Technical information

## FIT VOLT

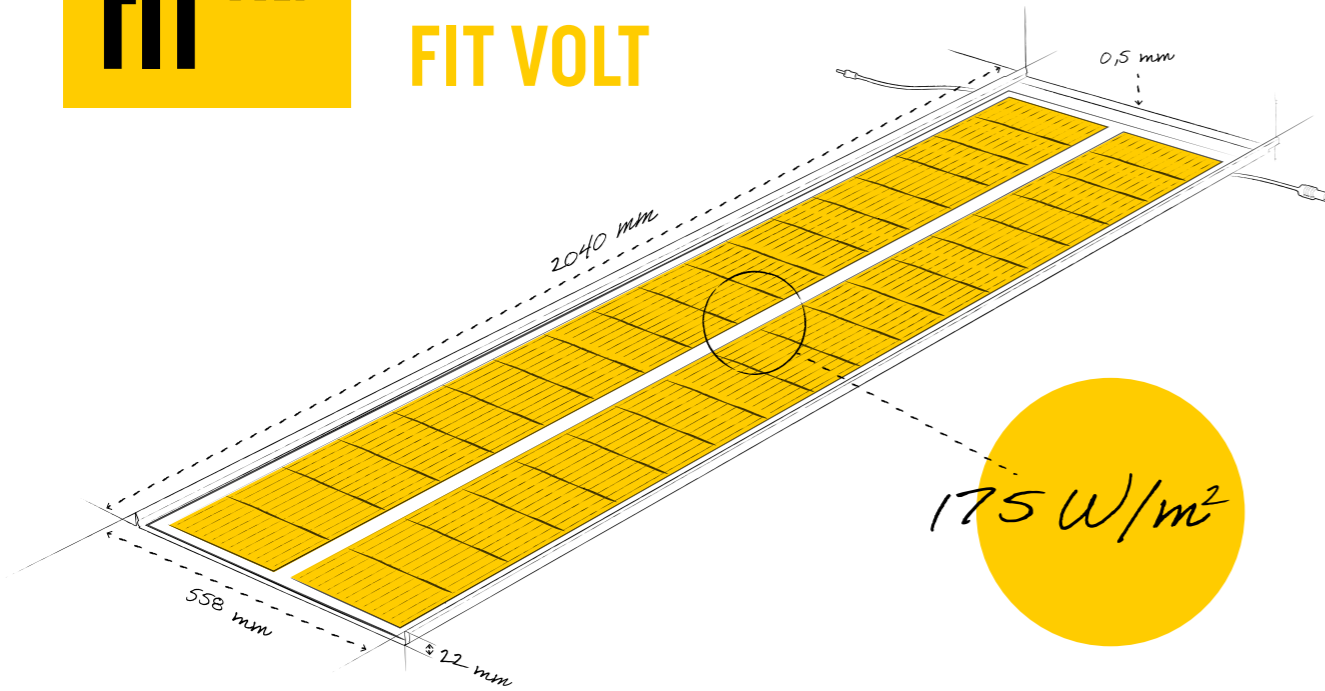

Number of cells	<b>36</b>	Cell type	<b>monocrystalline PERC 210mm Half-cut 2x18 cells</b>
Rated power [W]	<b>175</b>	Idle voltage [V]	<b>24</b>
Seam height [mm]	<b>22</b>	Installation	<b>snap lock (click)</b>
Total width [mm]	<b>558</b>	Effective width [mm]	<b>527</b>
Steel	<b>XCarb® ArcelorMittal</b>	Sheet thickness [mm]	<b>0,5</b>
Sheet length [mm]	<b>2040</b>	Overlap length when dividing sheets [mm]	<b>30</b>
Operating temperature range	<b>-40°C / +85°C</b>	J-box rating	<b>IP68</b>
Panel weight	<b>15 kg</b>	Roof inclination	<b>&gt;9°</b>

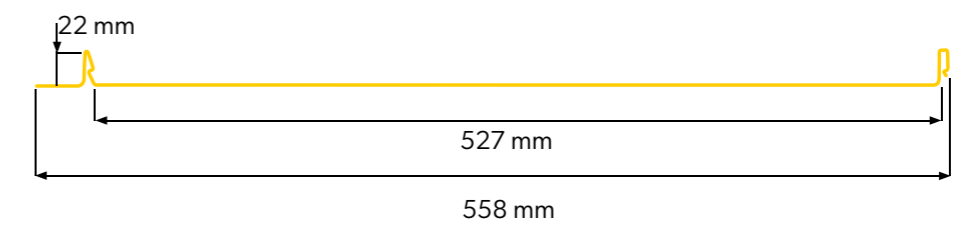

The photovoltaic modules are designed to meet numerous compliance requirements:  
 IEC 61215-1:2016 (functionality of PV modules), IEC 61730-1:2016 (safety of PV modules),  
 EN 13501-5:2016 BROOF (T1) (fire protection), ISO 9001:2015 (quality management systems).

You can find this product in our BP2 BIM library for architects and designers [www.bp2.eu/en/architects](http://www.bp2.eu/en/architects)





# 3.

## MODULAR SERIES

28. IZI ROOF

30. IZI LOOK

32. ZET ROOF

34. ZET LOOK

36. Colours

37. Feedstock

# MODULAR SERIES

MODULAR SERIES is a line of state-of-the-art modular roofing products, featuring innovative technological solutions and perfected aesthetics. The tiles are manufactured in the form of small two-module sheets which greatly facilitate and speed up transportation and installation.

The modular products are available in two fixing options: traditional with visible screws (IZI Roof and ZET Roof) and, for more demanding customers, with hidden screws (IZI Look and ZET Look).

Advanced technological solutions, representing proprietary innovations on the roofing market, made with attention to the finest details and flawless precision, thanks to automated production lines.

The MODULAR SERIES is distinguished by advantages unique to its product class:

- The form of the two-module sheets facilitates loading, transport and unloading and, above all, makes installation easier and faster. Lightweight and small sheets mean more convenient delivery to the roof and safe storage.
- The high „Z“ embossing is a legally protected solution that creates deep shadows between the modules, giving the covering a unique, dynamic form in all lighting conditions. The „Z“ locking joint additionally protects the cut edges against corrosion.
- Professional packaging includes polystyrene dividers, a special cover with reusable drawstrings, stretch films and binding tapes.
- A dedicated packaging system protects the modules, reducing the risk of damage and abrasion during loading, transport, and unloading.
- The warranty of up to 55 years for selected coatings is a confirmation of the high quality of the product in the roofing market, supported by objective laboratory tests carried out in the specialist BP2 laboratory. The steel supplied to BP2 is subjected to extensive testing and only its positive result qualifies it for tile production.
- Repeatability of colour and texture is guaranteed in the warranty certificate.
- Dedicated TORX screws (IZI Roof, ZET Roof) mean less visibility of the fasteners and consequently higher aesthetics of the roofing.





# Modular steel roof tile

## IZI Roof

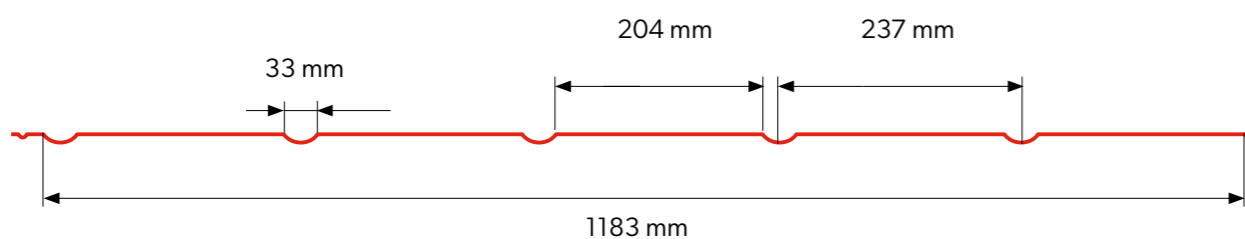
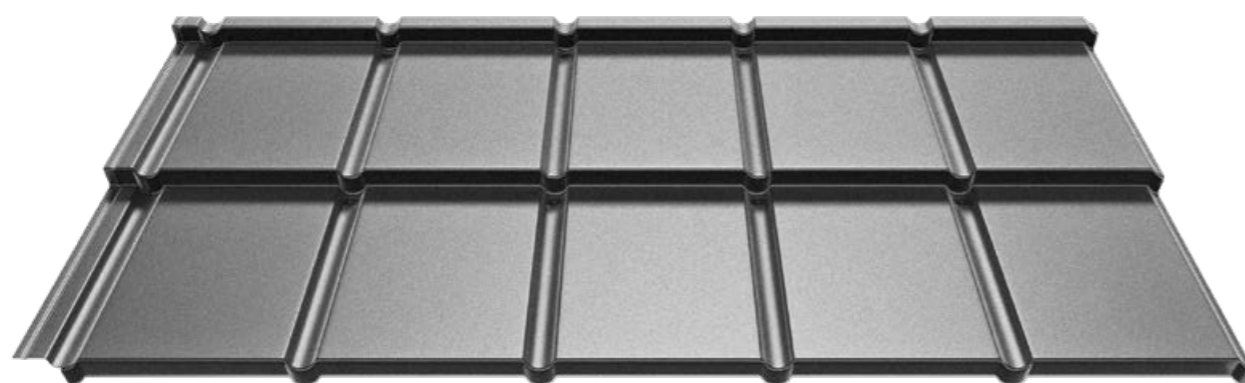

**Technical information [mm]**

Effective width	1183
Overall width	1233
Sheet thickness	0,5
Profile overall height	38
Embossing height	30
Module width	363 (batten span 350 mm)
Effective area (coverage) of a single sheet	0,828 m <sup>2</sup>
Weight	~ 4,5 kg/m <sup>2</sup>
Roof angle	>9°

### ANTI WAVE

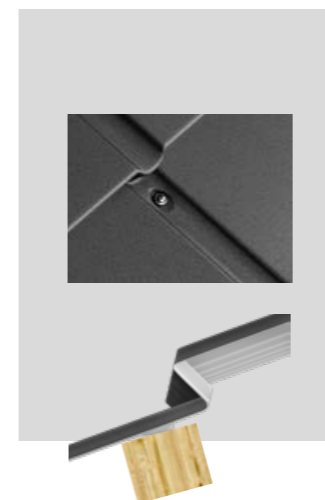

ANTI WAVE is a system of precisely shaped mounting recesses at the optimal points of the sheet for the installation of fixings. The main benefits of this solution are:

- the fixing points are optimised,
- stress and undulations of the flat surface are reduced,
- no need to plane the battens to the roof pitch,
- the recesses reduce the visibility of the fixings,
- the shape of the recesses facilitates drainage from the fixing points.

### EASY LINK

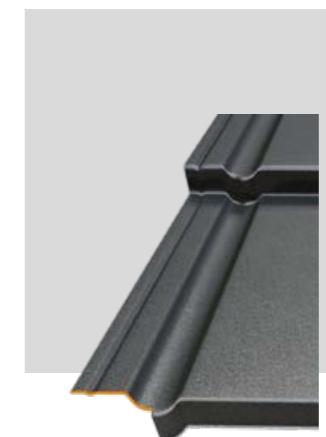

EASY LINK A proprietary solution that makes the sheets fit together like never before. In order to avoid the effect of overlapping sheets in the area where the three sheets join, the IZI modular roof tiles use a cut corner of the bottom embossing.

In addition, the specially shaped profile of the edge embossing allows the sheets to fit together perfectly without any visible longitudinal joints.

### "Z" EMBOSSING

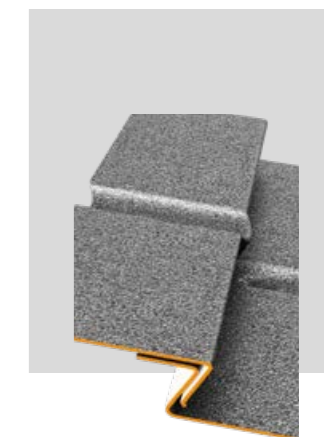

"Z" EMBOSSING is a corrugation technology using a proprietary "Z" type embossing, which creates deep shadows between the modules. This ensures that the covering presents a unique, dynamic form in all lighting conditions.

The shadow of the embossing makes horizontal joints between the sheets less visible. This has a major impact on the aesthetics of the roof covering.



You can find this product in our BP2 BIM library for architects and designers  
[www.bp2.eu/en/architects](http://www.bp2.eu/en/architects)





# Modular steel roof tile

## IZI Look

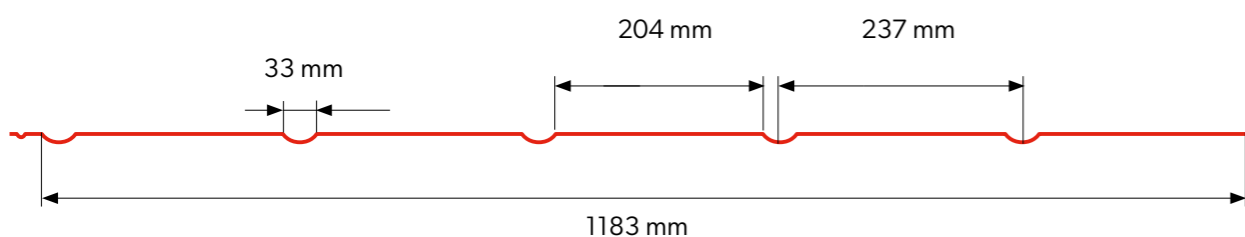
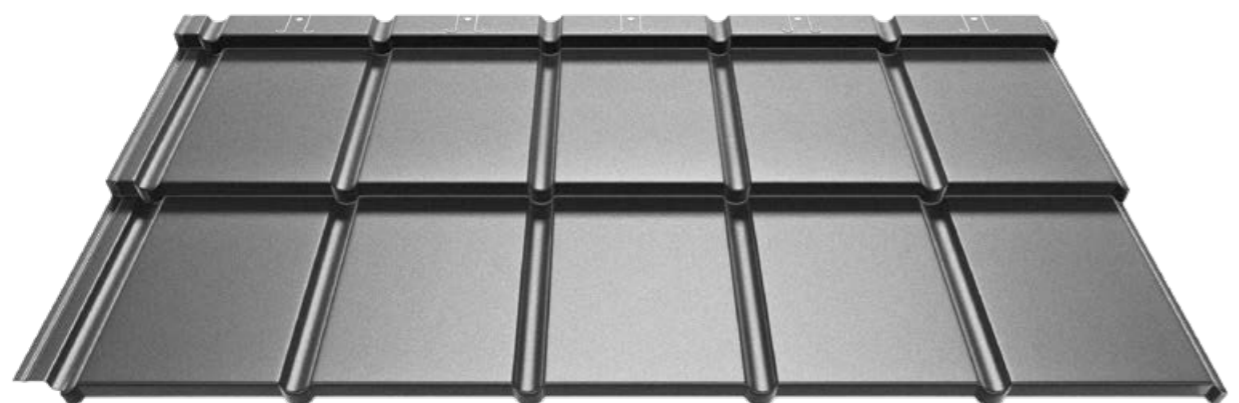

**Technical information [mm]**

Effective width	<b>1183</b>
Overall width	<b>1233</b>
Sheet thickness	<b>0,5</b>
Profile overall height	<b>38</b>
Embossing height	<b>30</b>
Module width	<b>363 (batten span 350 mm)</b>
Effective area (coverage) of a single sheet	<b>0,828 m<sup>2</sup></b>
Weight	<b>~ 4,5 kg/m<sup>2</sup></b>
Roof angle	<b>&gt;9°</b>

### OUT OF SIGHT



IZI Look modular metal roof tiles are aesthetically pleasing with no compromise.

A distinctive feature of these coverings is the elimination of screws visible on the roof surface so that the harmony is not disturbed by any fixing element or mounting elements holes.

### EASY LINK

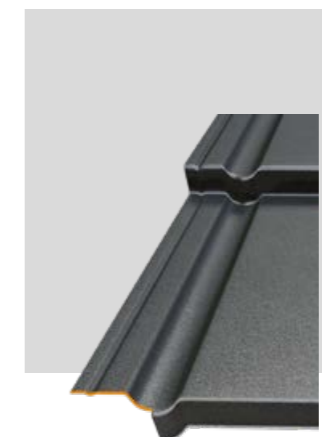

EASY LINK A proprietary solution that makes the sheets fit together like never before.

In order to avoid the effect of overlapping sheets in the area where the three sheets join, the IZI modular roof tiles use a cut corner of the bottom embossing.

In addition, the specially shaped profile of the edge embossing allows the sheets to fit together perfectly without any visible longitudinal joints.

### "Z" EMBOSSING



"Z" EMBOSSING is a corrugation technology using a proprietary "Z" type embossing, which creates deep shadows between the modules. This ensures that the covering presents a unique, dynamic form in all lighting conditions.

The shadow of the embossing makes horizontal joints between the sheets less visible. This has a major impact on the aesthetics of the roof covering.



You can find this product in our BP2 BIM library for architects and designers  
[www.bp2.eu/en/architects](http://www.bp2.eu/en/architects)







# Modular steel roof tile

## ZET Roof

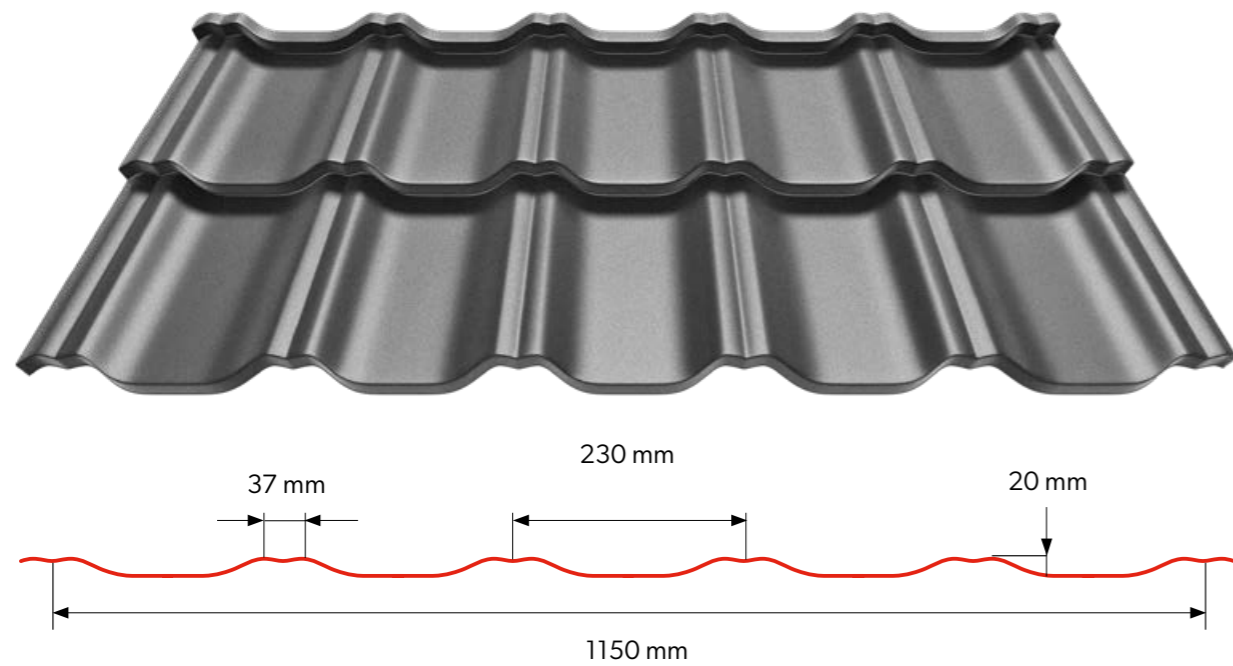

**Technical information [mm]**

Effective width	1150
Overall width	1212
Sheet thickness	0,5
Profile overall height	50
Embossing height	30
Module width	363 (batten span 350 mm)
Effective area (coverage) of a single sheet	0,805 m <sup>2</sup>
Weight	~ 4,5 kg/m <sup>2</sup>
Roof angle	>9°

### „Z“ EMBOSSING

The complete roof image consists not only of colour and shape, but also of the play of light and shadow. When creating our product, we paid attention to all these aspects. All this to design a roof covering that combines the highest aesthetics, functionality and durability, as well as safety and speed of installation. A ground-breaking corrugation technology using the „Z“ embossing creates deep shadows between the modules. This ensures that the covering presents a unique, dynamic form in all lighting conditions. The shadow of the embossing not only shapes the plastic image of the tile, but, above all, it makes screws and horizontal joints between the sheets less visible. This has a major impact on the aesthetics of the roof covering.

- screws hidden in the shadow,
- invisible horizontal joints,
- attractive and dynamic form.

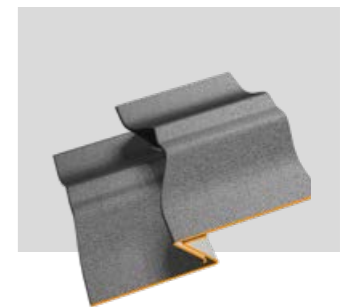

You can find this product in our BP2 BIM library for architects and designers  
[www.bp2.eu/en/architects](http://www.bp2.eu/en/architects)





# Modular steel roof tile

## ZET Look

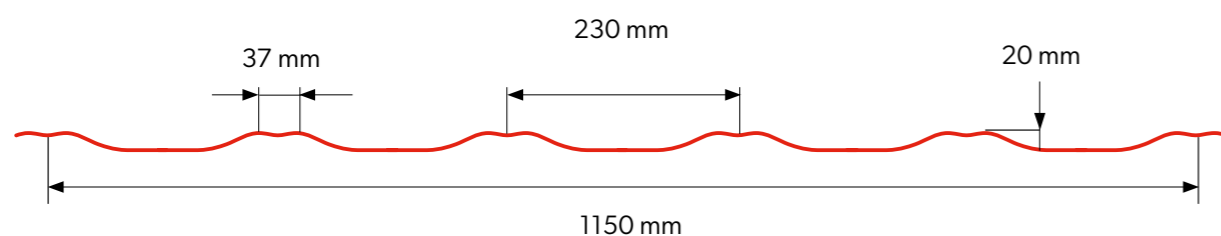

**Technical information [mm]**

Effective width	1150
Overall width	1212
Sheet thickness	0,5
Profile overall height	50
Embossing height	30
Module width	363 (batten span 350 mm)
Effective area (coverage) of a single sheet	0,805 m <sup>2</sup>
Weight	~ 4,5 kg/m <sup>2</sup>
Roof angle	>9°

### OUT OF SIGHT

ZET Look modular roof tiles stand for the highest aesthetics with no compromise. A distinctive feature of these coverings is the elimination of screws visible on the roof surface so that the harmony is not disturbed by any fixing element or mounting elements, holes. The installation system, designed together with master roofers, is very simple despite its technological advancement.



### „Z“ EMBOSSING

The complete roof image consists not only of colour and shape, but also of the play of light and shadow. When creating our product, we paid attention to all these aspects. All this to design a roof covering that combines the highest aesthetics, functionality and durability, as well as safety and speed of installation. A ground-breaking corrugation technology using the „Z“ embossing creates deep shadows between the modules. This ensures that the covering presents a unique, dynamic form in all lighting conditions. The shadow of the embossing not only shapes the plastic image of the tile, but, above all, it makes screws and horizontal joints between the sheets less visible. This has a major impact on the aesthetics of the roof covering.

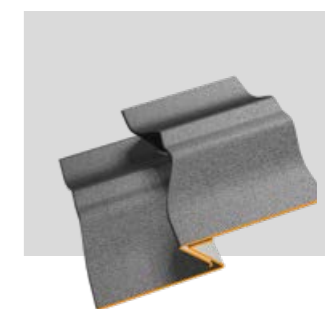

- screws hidden in the shadow,
- invisible horizontal joints,
- attractive and dynamic form.



You can find this product in our BP2 BIM library for architects and designers  
[www.bp2.eu/en/architects](http://www.bp2.eu/en/architects)



# Colours & warranty

## ULTIMAT [UTK]



A 35 µm thick coating with very high corrosion and UV resistance (RC4/RUV4). The ULTIMAT coating with its grained structure, inspired by nature, is free of chromium and heavy metals and is a green, recyclable product. Sheet metal coated with the ULTIMAT elastic coating can be profiled at extremely low temperatures.

Code	Coatings thickness	Corrosion resistance	UV resistance	Warranty period (years)
<b>ULTIMAT [UTK]</b>	<b>35 µm</b>	<b>RC4</b>	<b>RUV4</b>	<b>30</b>

## HERCULIT [HC]



It is a coating developed in close cooperation with a leading manufacturer of varnishes for the best steel mills in Europe. Many years of studying existing coatings and monitoring customer needs, with particular emphasis on the needs of roofers, have allowed us to condense so many different advantages into one product. HERCULIT is a polyurethane cured polyester with a high resistance to mechanical damage and a thickness of 35 µm.

Code	Coatings thickness	Corrosion resistance	UV resistance	Warranty period (years)
<b>HERCULIT [HC]</b>	<b>35 µm</b>	<b>RC4</b>	<b>RUV4</b>	<b>55</b>

# Feedstock - FIT, IZI, ZET

## COATED STEEL SHEETS [UTK, HC]

The input material used by us has been specially designed for modular roofing in close co-operation with steelworks. We paid particular attention to key properties which determine the quality and durability of such roof coverings.

Our tin sheets ensure very high consistency of coating colour and structure and display above average durability and anti-corrosion properties. This means that we can confidently offer long-term warranties, without the need to purchase additional elements which is often the case with our competitors' products.

Excellent resistance to abrasion, mechanical damage and sun radiation means that even after years of usage, the roofing looks fresh and elegant.

### Coated sheet cross-section

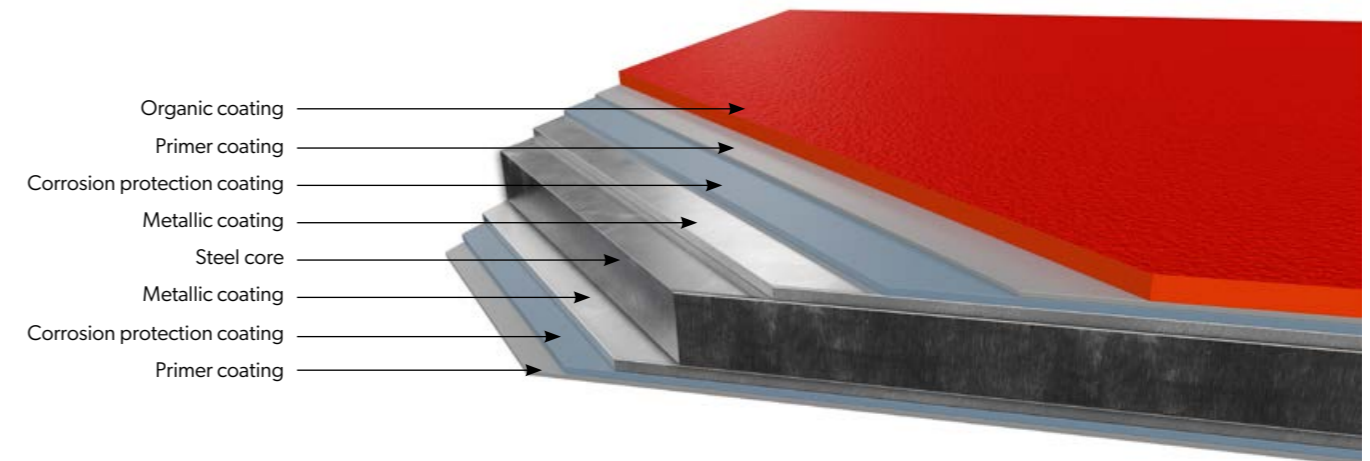

In 2022, after months of research, trials and many laboratory tests, it was possible to achieve a coating about 30% harder than the earlier version. HERCULIT [HC] is even more resistant to scratches, as well as to weathering or sunlight. At the same time, it has managed to maintain its flexibility, which is perfect for both installation and production of flashings. Thanks to all these parameters, it is an extremely durable product that will perform perfectly on the most demanding roof.



Printing technology does not allow for faithful colour rendition, so the colours shown are approximate and may differ from actual colours.



Detailed warranty conditions are specified in the warranty card. The warranty becomes valid after registration on the website [www.warranty.bp2.eu](http://www.warranty.bp2.eu)



**BP2 - Steel Stories**  
Scan code and learn more!



4.

**PANEL  
SERIES**

42. FIT

44. ZIPP

46. LAMBDA 2.0

# PANEL SERIES

Roof panels are distinguished by the speed of installation, while maintaining aesthetics by combining timeless forms with the latest technological solutions, such as MICRO RIB and MOLLET microprofiling, panel folding at the eaves part of the roof BEND LOCK, and cutting the corner of the embossment EASY LINK.

The construction of our roof panels provides more configuration possibilities, harmoniously harmonizing with the traditional architecture of small and large agglomerations, as well as modern design solutions for contemporary construction.





# FIT modular roof panel

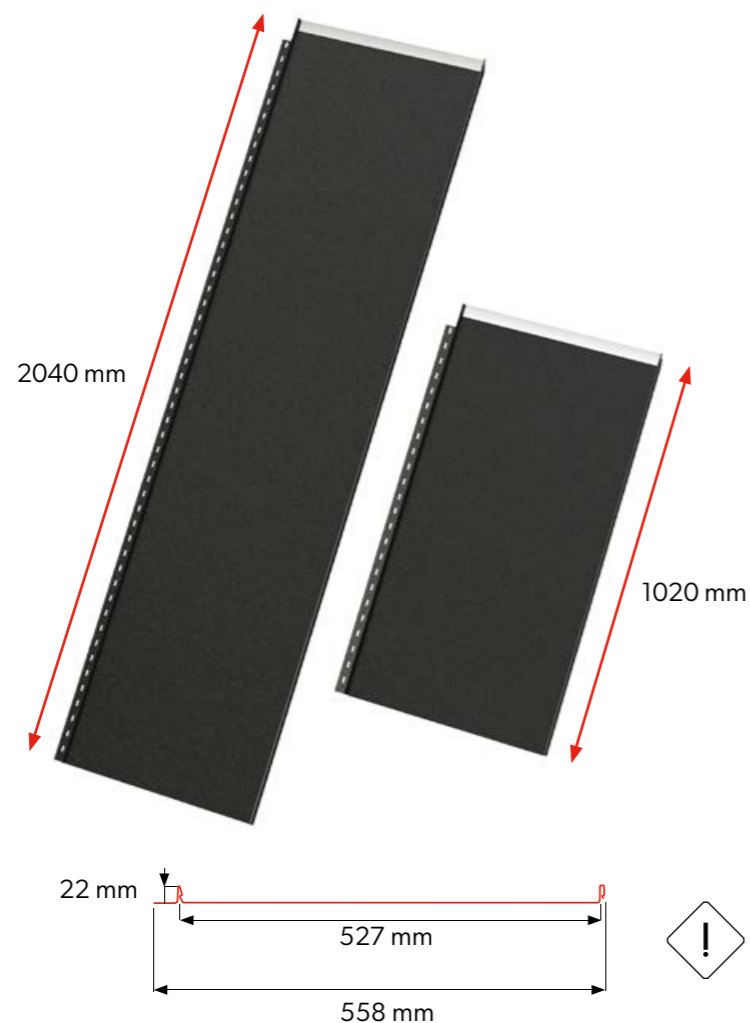

**!** The product is available in two standard lengths: **1020 mm i 2040 mm**

Technical information [mm]		
Nazewnictwo	FIT S	FIT L
Height rąbka	22	22
Overall width	558	558
Effective width	527	527
Sheet thickness	0,5	0,5
Module length	1020	2040
Tab length when splitting a sheet	30	30
Roof angle	>9°	

## BEND LOCK



The latest technology for impeccable roof appearance. A technical solution to fold the panel at the eaves part of the roof to conceal and protect the cut edge and eliminate the need to install screws. In addition, the lower BEND LOCK fold is cut at an angle, which makes it easier to guide and connect the panels along their length.

## EASY LINK

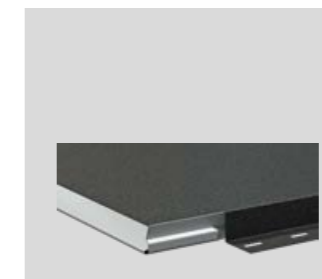

The sheets fit together like never before. The proprietary use consists of cutting the crease corner to avoid the overlapping of the three layers of metal sheets at the connection point. In addition, a specially shaped profile of extreme ribs allows the sheets to fit perfectly without visible longitudinal joints.

## SEAL PROTECT



Additional protection against changing weather conditions. At the production stage, a special sealant is pressed into the fold of the sheet. It is distinguished by high flexibility and resistance to changing weather conditions.

## MODULARITY

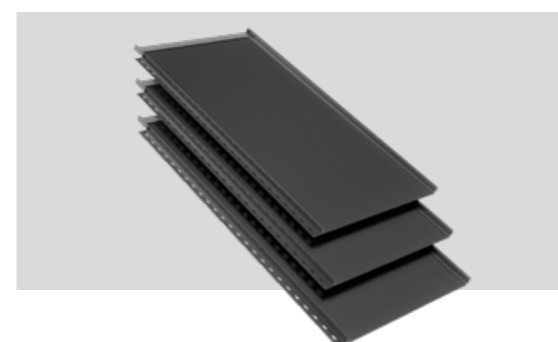

Modernity, efficiency, functionality. The modularity of the panel has many advantages – it significantly speeds up the assembly, enables easier transport, and the proprietary connection systems facilitate the entire installation process. An additional advantage is the visual effect that refers to traditional roofing.

## FLAT SURFACE & MICRO RIB

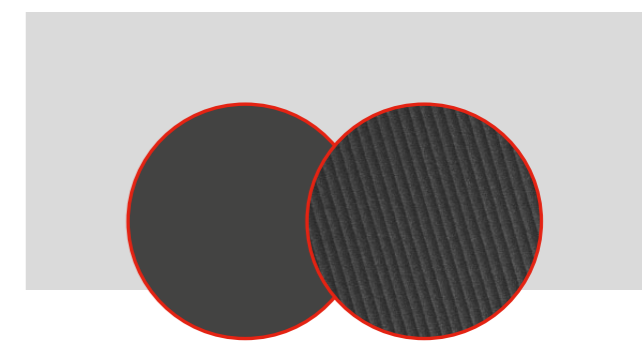

Currently in our offer, FIT modular roof panels are available in two finishes: FLAT and MICRO RIB [M].



You can find this product in our BP2 BIM library for architects and designers  
[www.bp2.eu/en/architects](http://www.bp2.eu/en/architects)





# ZIPP roof panels

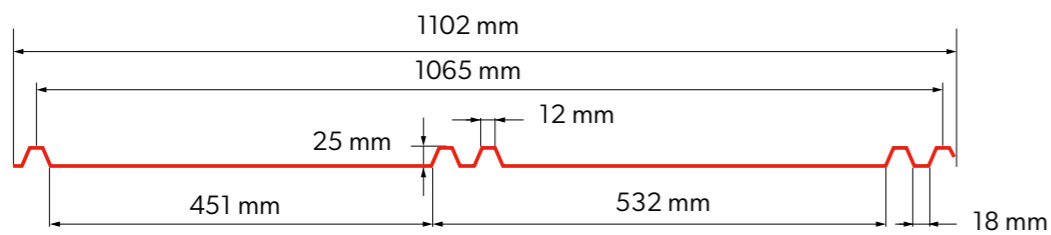
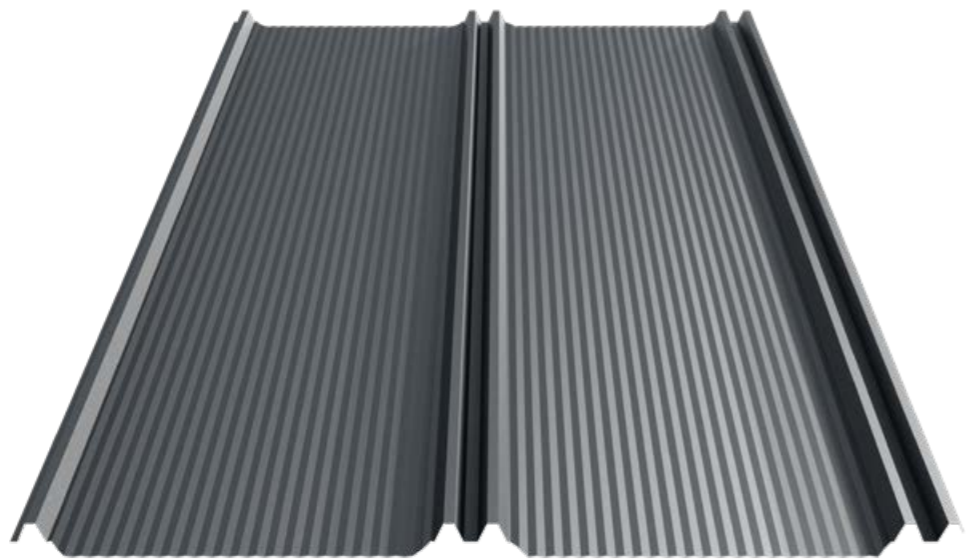

Technical information [mm]	
Height profilu	25
Overall width	1102
Effective width	1065
Sheet thickness	0,5-0,7
Module length	min. 1000 max. 8 000
Roof angle	>9°

## BEND LOCK

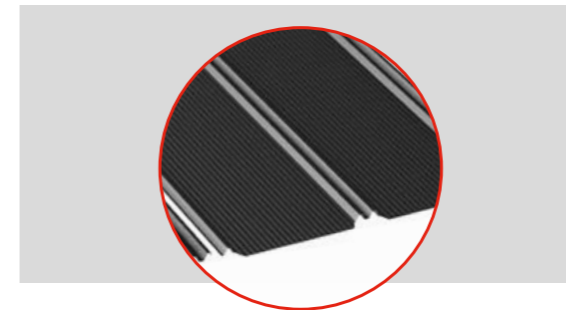

It secures the cut edge and eliminates the need to use screws.

## MICRO RIB [20]

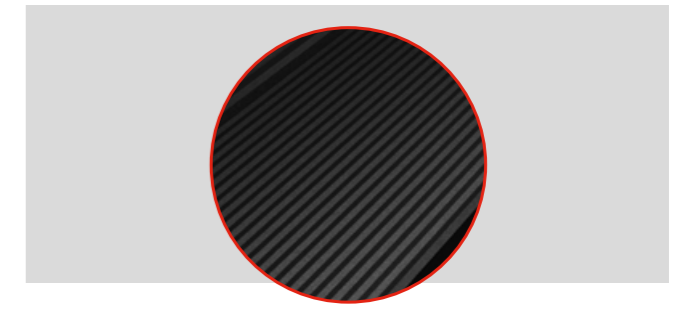

The double width, compared to standard roof panels, enables roof covering costs optimization.

## QUICK INSTALLATION



The shape and technologies of the ZIPP panel ensure simple and quick installation on the roof.

## EFFICIENT WIDE PROFILE

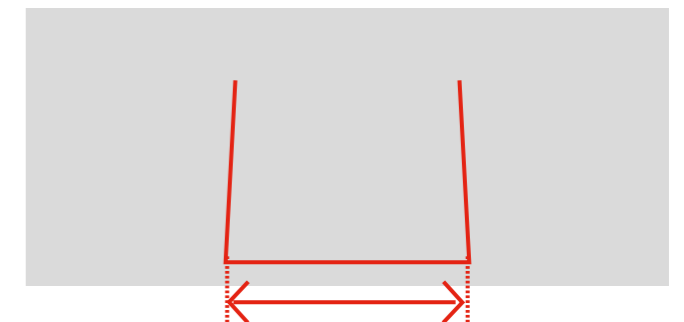

It helps optimize roofing costs.



You can find this product in our BP2 BIM library for architects and designers  
[www.bp2.eu/en/architects](http://www.bp2.eu/en/architects)



# LAMBDA 2.0

## LAMBDA 2.0 roof panels

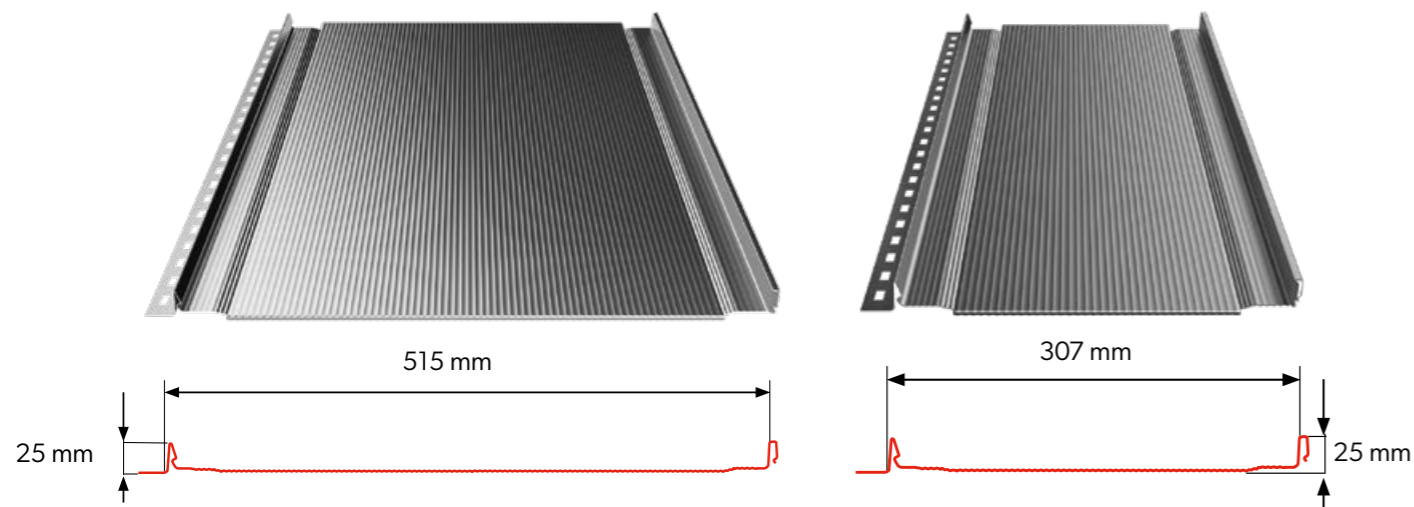

The product is available in two standard widths:  
**515 mm i 307 mm**

Technical information [mm]		
Designation	<b>L.2.0.515</b>	<b>L.2.0.307</b>
Seam height	<b>25</b>	<b>25</b>
Effective width	<b>515</b>	<b>307</b>
Overall width	<b>~547</b>	<b>~339</b>
Sheet thickness	<b>0,5 - 0,7</b>	<b>0,5 - 0,7</b>
Sheet length	<b>min. 1000 max. 10 000</b>	
Roof angle	<b>&gt;9°</b>	

### MICRO RIB

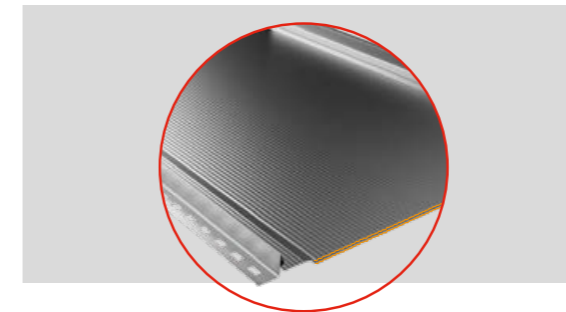

Minimizes the effect of waviness.

Longitudinal micro-corrugation across the entire surface of the sheet minimises the possibility of wave effect on the flat part of the panel.

### COVER CAP

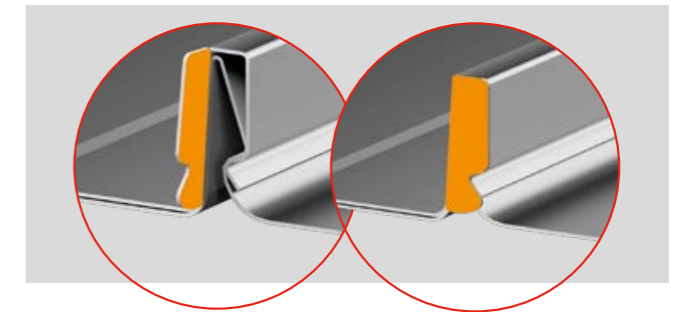

Functionality and aesthetics.

A solution which additionally increases the functionality of the covering is the COVER CAP element, i.e. panel seam caps on both sides. This solution also increases the visual effect and aesthetics of the covering. The COVER CAPs are bent after the installation of the roofing, hiding the visible joint between the sheets and ensuring that the roof presents a uniform, harmonious surface even from up close.

### BEND LOCK

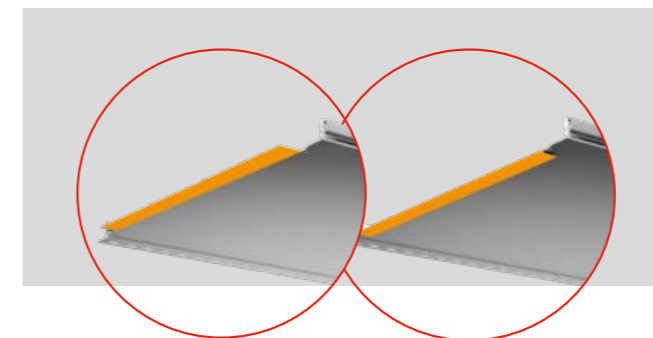

Installation without screws.

A special panel fold at the eaves part of the roof covers and secures the cut edge and eliminates the need to install screws.



You can find this product in our BP2 BIM library for architects and designers  
[www.bp2.eu/en/architects](http://www.bp2.eu/en/architects)





**MICRO RIB [M]**

The longitudinal micro-corrugation on the entire surface of the sheet minimises the possibility of ripple effect on the flat part of the panel.



You can find this product in our BP2 BIM library for architects and designers  
[www.bp2.eu/en/architects](http://www.bp2.eu/en/architects)



You can find this product in our BP2 BIM library for architects and designers  
[www.bp2.eu/en/architects](http://www.bp2.eu/en/architects)

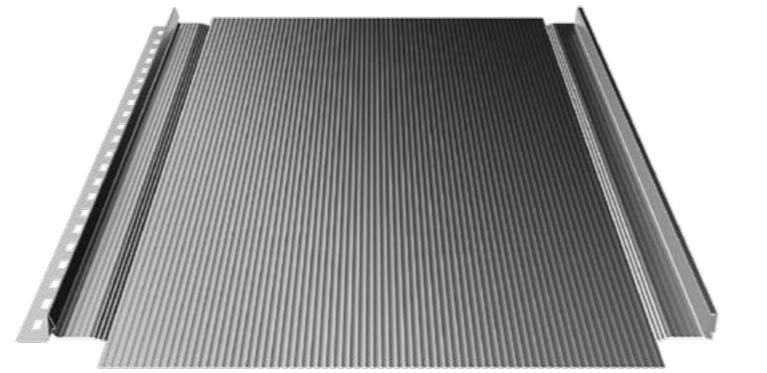

**Product code:**  
**LW.2.0.515.M**

LAMBDA 2.0 roof panel with MICRO RIB longitudinal micro-corrugation and cut-out for folding.

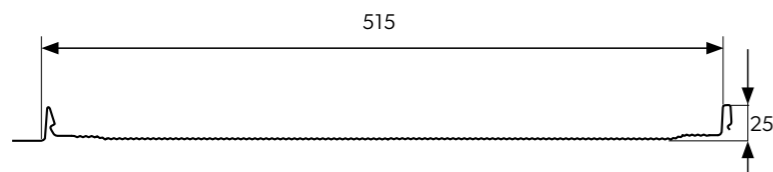

**Product code:**  
**LW.2.0.515.R**

LAMBDA 2.0 roof panel with double semicircular corrugation and cut-out for folding.

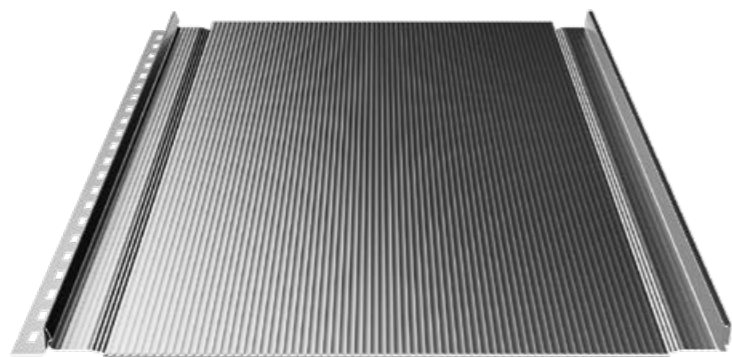
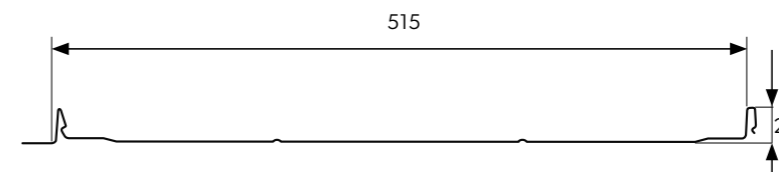

**Product code:**  
**LWZ.2.0.515.M**

LAMBDA 2.0 roof panel with MICRO RIB longitudinal micro-corrugation and BEND LOCK fold.

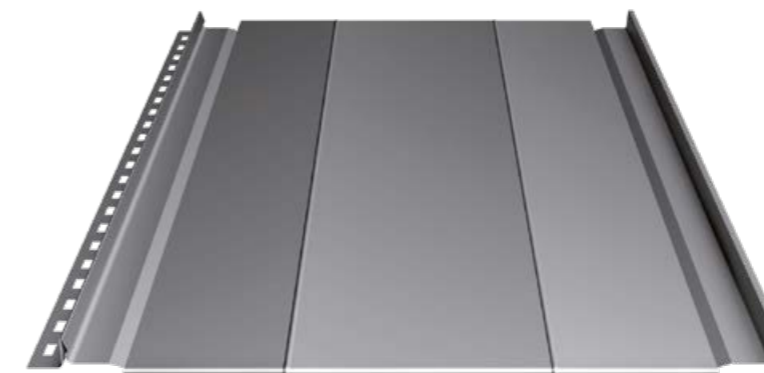
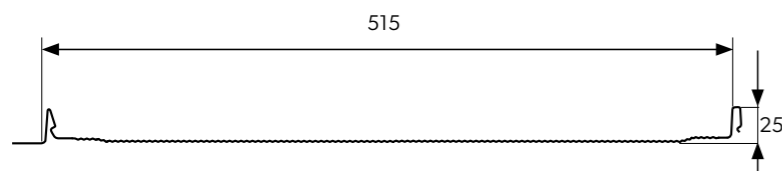

**Product code:**  
**LWZ.2.0.515.R**

LAMBDA 2.0 roof panel with double semicircular corrugation and BEND LOCK fold.

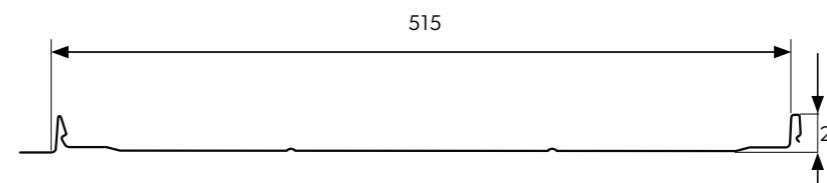

**TYPE [T25] CORRUGATION**

Finishing of the panel surface with longitudinal corrugation in the shape of a wide trapezoid.



You can find this product in our BP2 BIM library for architects and designers  
[www.bp2.eu/en/architects](http://www.bp2.eu/en/architects)

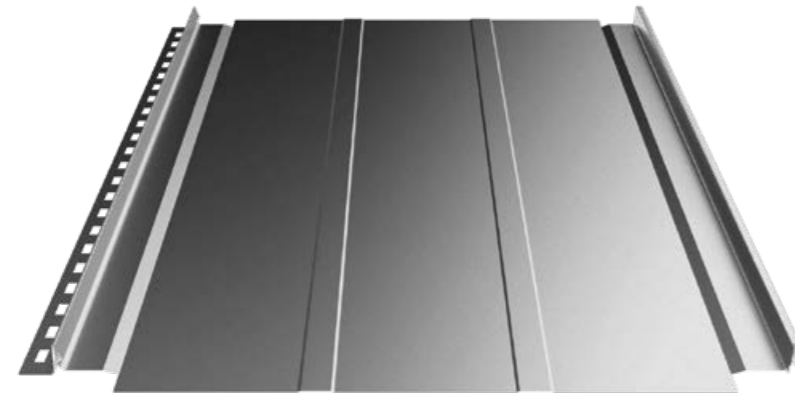

**Product code:**  
**LW.2.0.515.T25**

LAMBDA 2.0 roof panel with double trapezoidal corrugation and cut-out for folding.

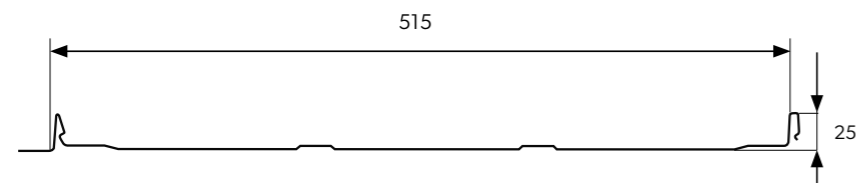

**SHEET WITHOUT CORRUGATION [P]**

Classic panel surface without any corrugation.



You can find this product in our BP2 BIM library for architects and designers  
[www.bp2.eu/en/architects](http://www.bp2.eu/en/architects)



**Product code:**  
**LW.2.0.515.P**

LAMBDA 2.0 roof panel with flat surface and cut-out for folding.

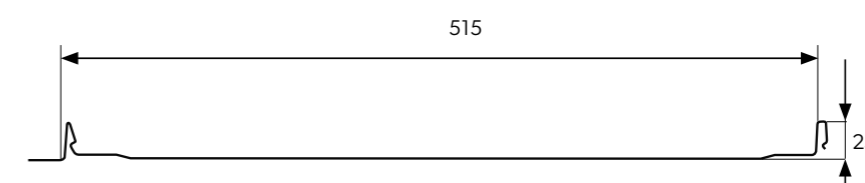

**Product code:**  
**LWZ.2.0.515.T25**

LAMBDA 2.0 roof panel with double trapezoidal corrugation and BEND LOCK fold.

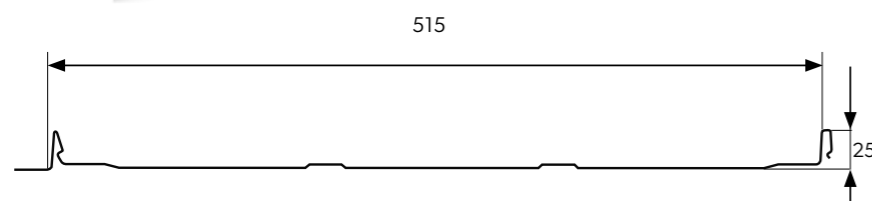

**Product code:**  
**LWZ.2.0.515.P**

LAMBDA 2.0 roof panel with flat surface and BEND LOCK fold.

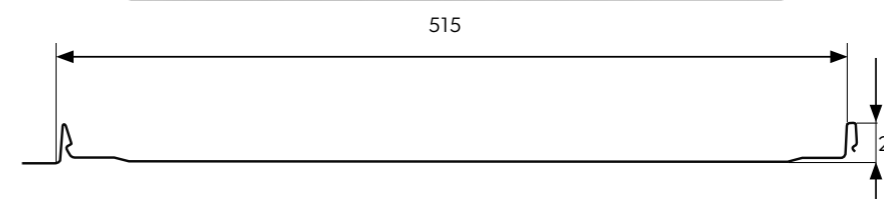

**ATTENTION!** Due to the construction of the roof panels, it is possible that the effect of so-called „waving“ of the metal sheet on the roofing occurs. This is a natural phenomenon for this type of product.

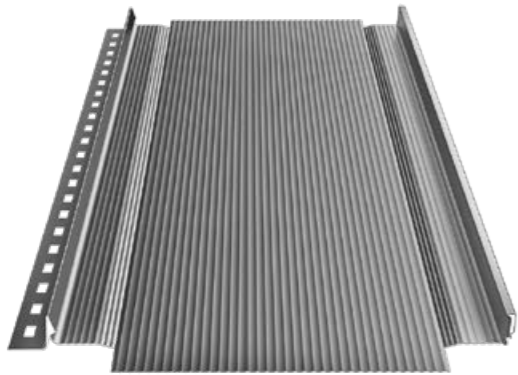

Product code: LW.2.0.307.M

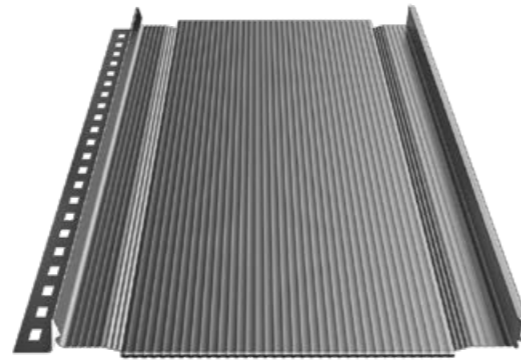
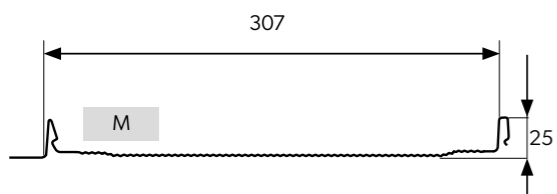

Product code: LWZ.2.0.307.M

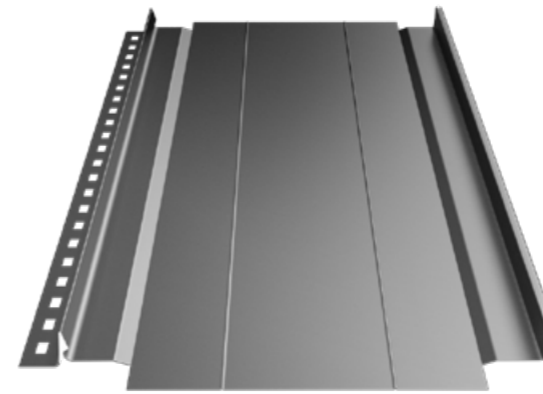
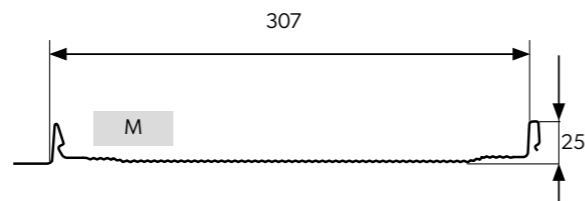

Product code: LW.2.0.307.R

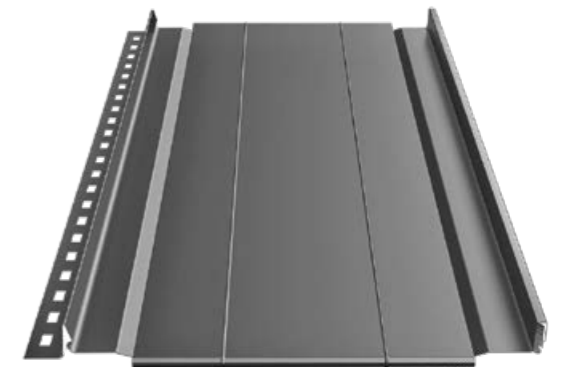

Product code: LWZ.2.0.307.R

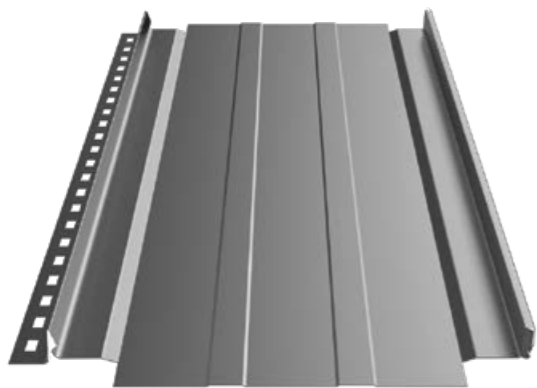
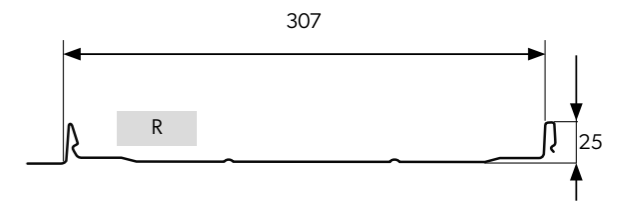

Product code: LW.2.0.307.T25

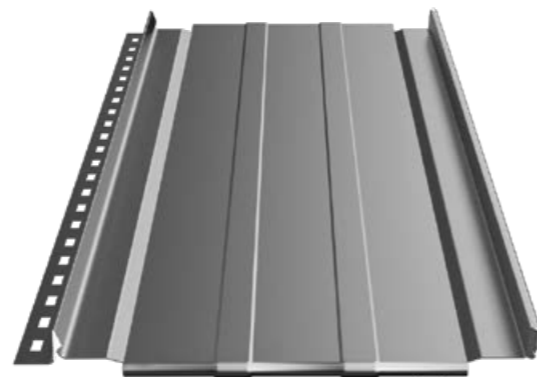
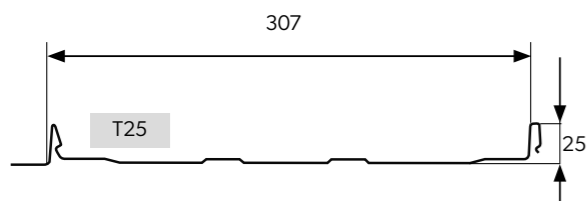

Product code: LWZ.2.0.307.T25

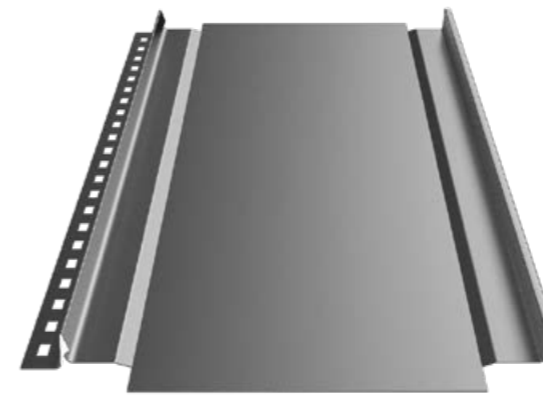
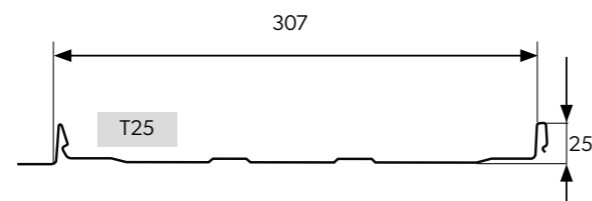

Product code: LW.2.0.307.P

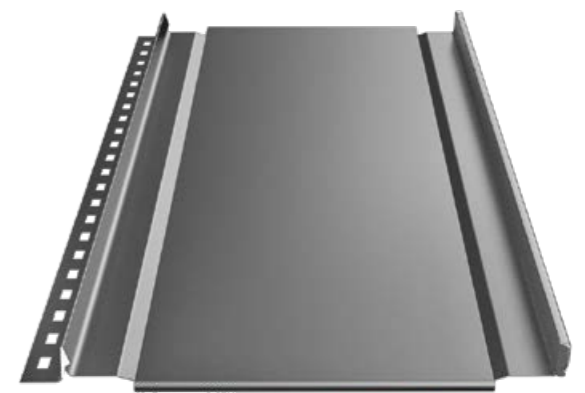
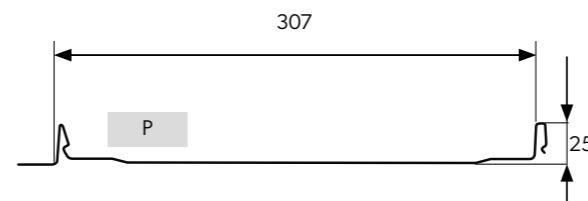

Product code: LWZ.2.0.307.P

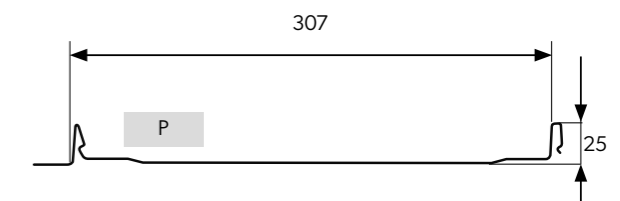

You can find this product in our BP2 BIM library for architects and designers  
[www.bp2.eu/en/architects](http://www.bp2.eu/en/architects)



ATTENTION! Due to the construction of the roof panels, it is possible that the effect of so-called „waving“ of the metal sheet on the roofing occurs. This is a natural phenomenon for this type of product.



# 5.

## COMPACT SERIES

58. IZI 2.0

60. FINN 2.0

61. ALFA 2.0

62. HETA 2.0

63. GAMMA 2.0

64. STIGMA 2.0

65. BAVARIA Roof 2.0

# COMPACT SERIES

COMPACT SERIES is a product line combining the advantages of cut-to-size tiles and modular solutions. It is a roofing material produced on the basis of classic metal tiles in the form of lightweight two-module sheets.

Like the modular tiles, the COMPACT SERIES products have a number of advantages in terms of transport, installation and storage. The COMPACT SERIES include profiles which are renowned on the market for classic tile roofing in their lightweight two-module form: FINN 2.0, ALFA 2.0, GAMMA 2.0, HETA 2.0, STIGMA 2.0 and BAVARIA Roof 2.0

We present the most important features of the COMPACT SERIES roof tiles:

- The form of the two-module sheets facilitates loading, transport and unloading and, above all, makes installation easier and faster. Lightweight and small sheets mean more convenient delivery to the roof and safe storage.
- A 3D wave-shaped cut that conceals the horizontal joints of the sheets, significantly improving the aesthetics of the roof finish.
- Pre-punched mounting holes on the vertical embossing which enable the sheets to be fitted together quickly and tightly. Not only does it make installation easier, but it also speeds up the work considerably.
- EASY LINK is an original solution used in the HETA 2.0 and ALFA 2.0 compact roof tiles, thanks to which the sheets fit together like never before.
- A special cut and profiling of the outermost embossing allow perfect fitting of the sheets at the point of contact.
- Dedicated TORX screws mean less visibility of the fasteners and consequently higher aesthetics of the roofing.
- Available in a wide range of colours and coatings.



Products from COMPACT SERIES are delivered on a pallet in a single stack



30/350



# Compact roof tiles

## IZI 2.0

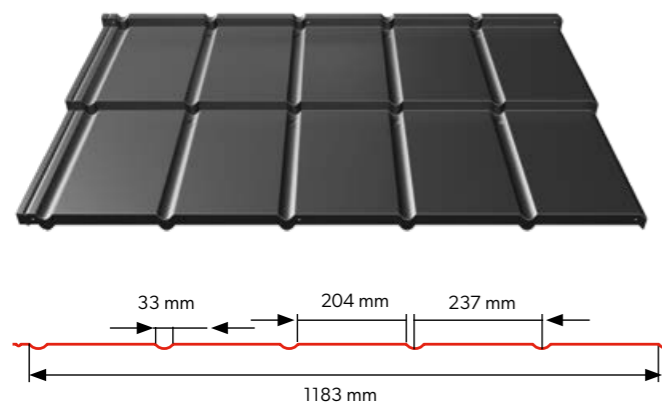

IZI 2.0 - Technical information [mm]	
Effective width	1183
Overall width	1233
Sheet thickness	0,5
Profile overall height	38
Embossing height	30
Module width	350 (batten span 350 mm)
Effective area (coverage) of a single sheet	0,828 m <sup>2</sup>
Weight	~ 4,5 kg/m <sup>2</sup>
Roof angle	>9°

### MOUNTING RECESSES



The specially thought-out installation recesses create a shadow to effectively minimise the visibility of installation screws. These recesses also serve as markers, indicating the connection points between the sheets and the roof structure.

### 3D SHAPED CUT



IZI 2.0 compact roof tiles are wave-shape cut so that the horizontal joints of the sheets are less visible.

### PRE-PUNCHED MOUNTING HOLES

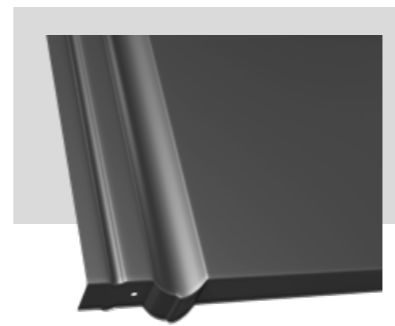

Pre-punched mounting holes on the vertical embossing enable the sheets to be fitted together quickly and tightly. Not only does it make installation easier, but it also speeds up the work considerably.



You can find this product in our BP2 BIM library for architects and designers  
[www.bp2.eu/en/architects](http://www.bp2.eu/en/architects)



30/350

# FINN 2.0 Compact roof tiles

## FINN 2.0

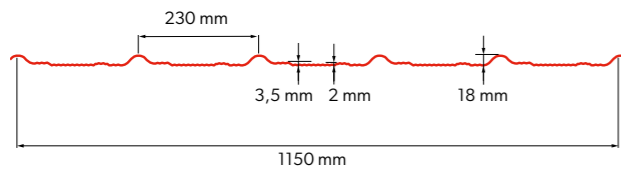

FINN 2.0 - Technical information [mm]	
Effective width	1150
Overall width	1190
Sheet thickness	0,5
Profile overall height	48
Embossing height	30
Module width	350
Effective area (coverage) of a single sheet	0,805 m <sup>2</sup>
Weight	~ 4,5 kg/m <sup>2</sup>
Roof angle	>9°

### Symmetrical profile

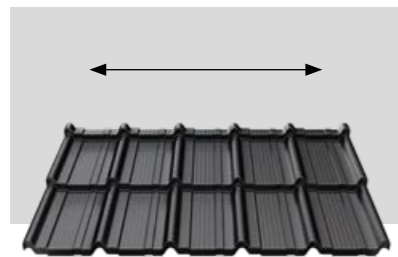

The design of FINN 2.0 compact tiles allows for installation in any direction (left or right).

### 3D shaped cut

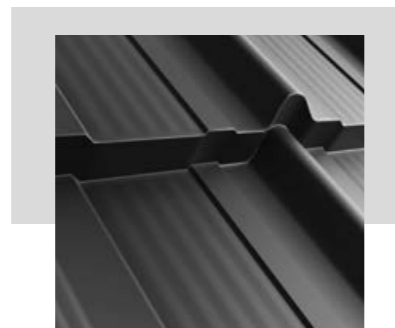

FINN 2.0 compact roof tiles are wave-shape cut so that the horizontal joints of the sheets are less visible.

### Pre-punched mounting holes

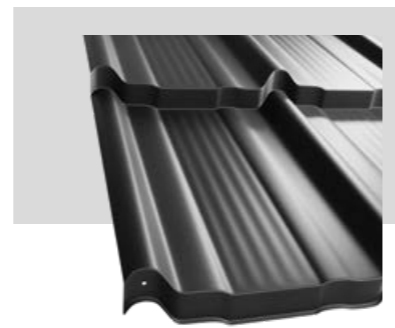

Pre-punched mounting holes on the vertical embossing enable the sheets to be fitted together quickly and tightly. Not only does it make installation easier, but it also speeds up the work considerably.



You can find this product in our BP2 BIM library for architects and designers  
[www.bp2.eu/en/architects](http://www.bp2.eu/en/architects)



30/350  
35/350

# ALFA 2.0 Compact roof tiles

## ALFA 2.0

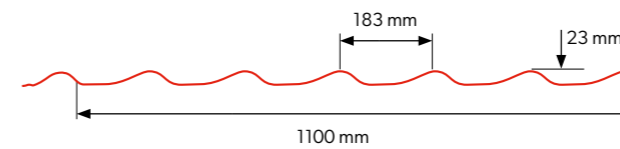

ALFA 2.0 - Technical information [mm]	
Effective width	1100
Overall width	1183
Sheet thickness	0,5
Profile overall height	53/58
Embossing height	30/35
Module width	350
Effective area (coverage) of a single sheet	0,770 m <sup>2</sup>
Weight	~ 4,5 kg/m <sup>2</sup>
Roof angle	>9°

### EASY LINK

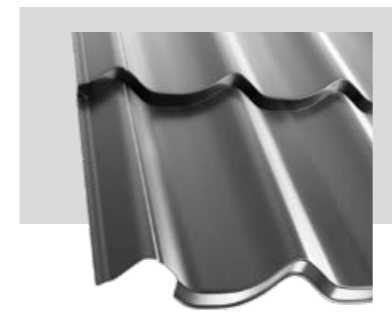

A proprietary solution that makes the sheets fit together like never before. A special cut and profiling of the outermost embossing allow perfect fitting of the sheets at the point of contact.

### 3D shaped cut



ALFA 2.0 compact roof tiles are wave-shape cut so that the horizontal joints of the sheets are less visible.

### Pre-punched mounting holes



Pre-punched mounting holes on the vertical embossing enable the sheets to be fitted together quickly and tightly. Not only does it make installation easier, but it also speeds up the work considerably.



You can find this product in our BP2 BIM library for architects and designers  
[www.bp2.eu/en/architects](http://www.bp2.eu/en/architects)



30/350  
40/350

# HETA 2.0 Compact roof tiles

## HETA 2.0

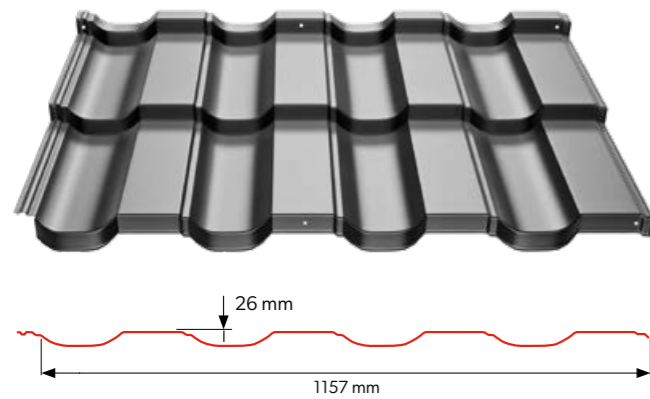

HETA 2.0 - Technical information [mm]	
Effective width	1157
Overall width	1202
Sheet thickness	0,5
Profile overall height	56/66
Embossing height	30/40
Module width	350
Effective area (coverage) of a single sheet	0,810 m <sup>2</sup>
Weight	~ 4,5 kg/m <sup>2</sup>
Roof angle	>9°

30/350  
40/350

# GAMMA 2.0 Compact roof tiles

## GAMMA 2.0

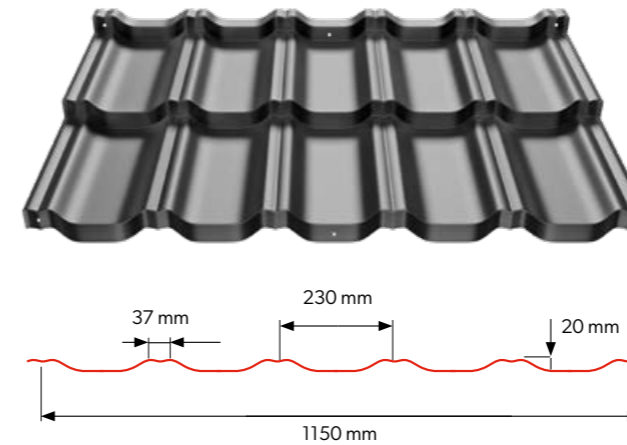

GAMMA 2.0 - Technical information [mm]	
Effective width	1150
Overall width	1212
Sheet thickness	0,5
Profile overall height	50/60
Embossing height	30/40
Module width	350
Effective area (coverage) of a single sheet	0,805 m <sup>2</sup>
Weight	~ 4,5 kg/m <sup>2</sup>
Roof angle	>9°

### EASY LINK

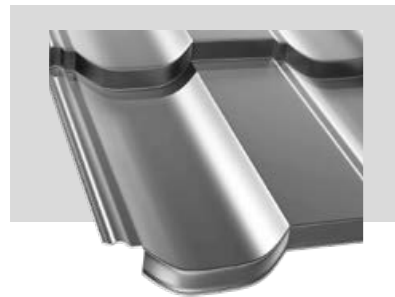

A proprietary solution that makes the sheets fit together like never before. A special cut and profiling of the outermost embossing allow perfect fitting of the sheets at the point of contact.

### 3D shaped cut



HETA 2.0 compact roof tiles are wave-shape cut so that the horizontal joints of the sheets are less visible.

### Pre-punched mounting holes

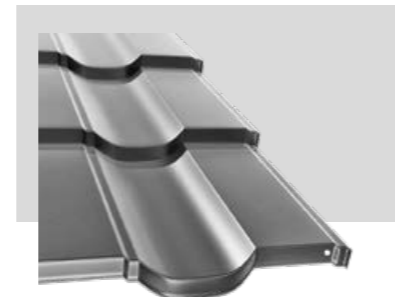

Pre-punched mounting holes on the vertical embossing enable the sheets to be fitted together quickly and tightly. Not only does it make installation easier, but it also speeds up the work considerably.

### Symmetrical profile

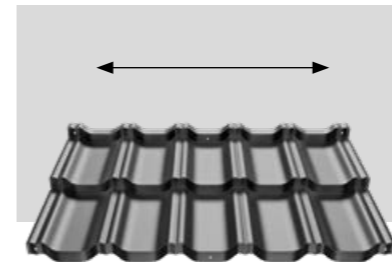

The design of GAMMA 2.0 compact tiles allows for installation in any direction (left or right).

### 3D shaped cut



GAMMA 2.0 compact roof tiles are wave-shape cut so that the horizontal joints of the sheets are less visible.

### Pre-punched mounting holes

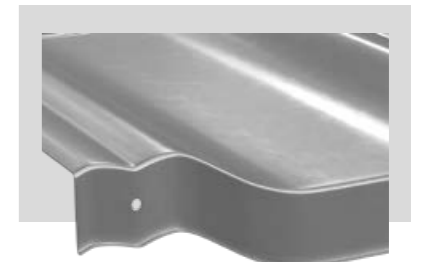

Pre-punched mounting holes on the vertical embossing enable the sheets to be fitted together quickly and tightly. Not only does it make installation easier, but it also speeds up the work considerably.



You can find this product in our BP2 BIM library for architects and designers  
[www.bp2.eu/en/architects](http://www.bp2.eu/en/architects)



You can find this product in our BP2 BIM library for architects and designers  
[www.bp2.eu/en/architects](http://www.bp2.eu/en/architects)





30/350  
40/350

# STIGMA 2.0 Compact roof tiles

## STIGMA 2.0

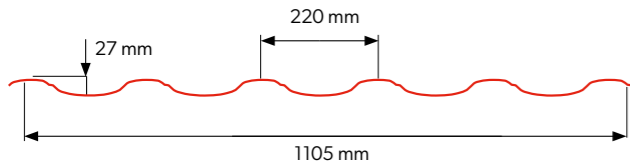

### FINN 2.0 - Technical information [mm]

Effective width	1105
Overall width	1194
Sheet thickness	0,5
Profile overall height	57 / 67
Embossing height	30 / 40
Module width	350
Effective area (coverage) of a single sheet	0,774 m <sup>2</sup>
Weight	~ 4,5 kg/m <sup>2</sup>
Roof angle	>9°

### Symmetrical profile

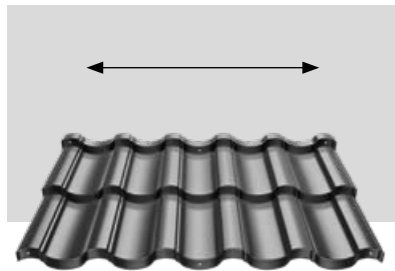

The design of STIGMA 2.0 compact tiles allows for installation in any direction (left or right).

### 3D shaped cut



STIGMA 2.0 compact roof tiles are wave-shape cut so that the horizontal joints of the sheets are less visible.

### Pre-punched mounting holes

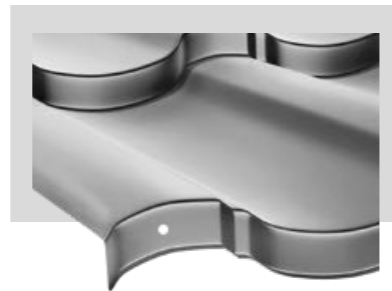

Pre-punched mounting holes on the vertical embossing enable the sheets to be fitted together quickly and tightly. Not only does it make installation easier, but it also speeds up the work considerably.



You can find this product in our BP2 BIM library for architects and designers  
[www.bp2.eu/en/architects](http://www.bp2.eu/en/architects)



# BAVARIA<sup>ROOF</sup> 2.0 Compact roof tiles

## BAVARIA Roof 2.0

30/350  
40/350

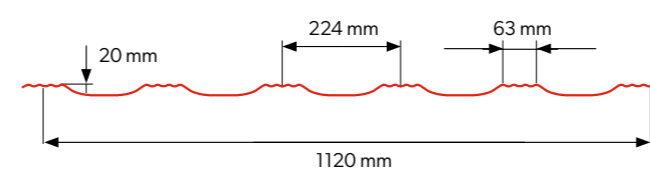
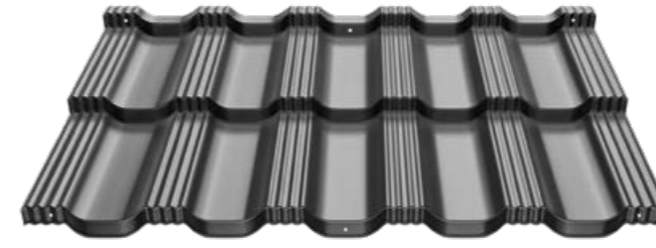

### BAVARIA Roof 2.0 - Technical information [mm]

Effective width	1120
Overall width	1206
Sheet thickness	0,5
Profile overall height	50/60
Embossing height	30/40
Module width	350
Effective area (coverage) of a single sheet	0,784 m <sup>2</sup>
Weight	~ 4,5 kg/m <sup>2</sup>
Roof angle	>9°

### Symmetrical profile

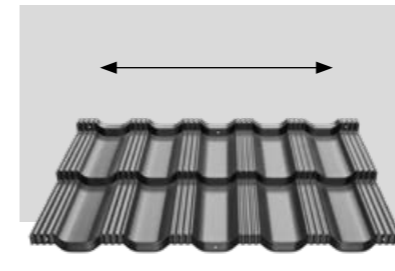

The design of BAVARIA Roof 2.0 compact tiles allows for installation in any direction (left or right).

### 3D shaped cut



BAVARIA Roof 2.0 compact roof tiles are wave-shape cut so that the horizontal joints of the sheets are less visible.

### Pre-punched mounting holes

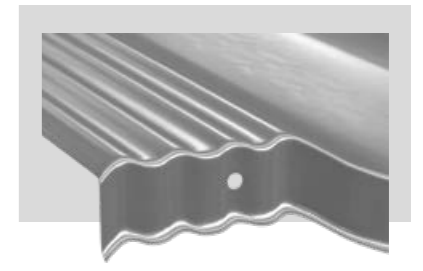

Pre-punched mounting holes on the vertical embossing enable the sheets to be fitted together quickly and tightly. Not only does it make installation easier, but it also speeds up the work considerably.



You can find this product in our BP2 BIM library for architects and designers  
[www.bp2.eu/en/architects](http://www.bp2.eu/en/architects)





6.

## CLASSIC SERIES

70. FINN

72. ALFA

73. GAMMA

74. STIGMA

75. BAVARIA Roof

# CLASSIC SERIES

CLASSIC SERIES is a line of popular sheet metal roofing products cut to size to perfectly match your roof design. The line of classic tile roofs includes well-established products: ALFA, GAMMA, STIGMA, BAVARIA Roof and completely new FINN.

The most important features of CLASSIC SERIES tiles:

- Metal sheets cut to dimension are perfectly matched to a specific roof design.
- The 3D cutting according to the wave shape that hides the horizontal joints of the sheets, significantly improves the aesthetics of the roof finish.
- The ready-made holes in the vertical ribs facilitate fast and tight fitting of the sheets. It is not only easier installation but also much shorter installation time (applies to version with rib 30mm and higher).
- Available in all colours, thicknesses and coating types.
- EASY LINK – authorial solution implemented in ALFA roofing tiles to match the sheets like never before. Special cut-out and profile of the extreme rib allows perfect match of the sheets at the connection point.





25/350  
25/400  
30/350



You can find this product in our BP2 BIM library for architects and designers  
[www.bp2.eu/en/architects](http://www.bp2.eu/en/architects)

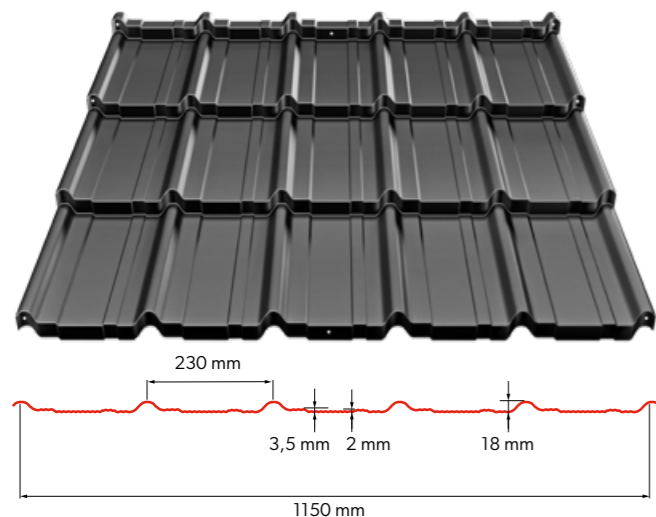

**FINN - Technical information [mm]**

Effective width	<b>1150</b>
Overall width	<b>1190</b>
Sheet thickness	<b>0,5</b>
Profile overall height	<b>43/48</b>
Embossing height for module 350	<b>25/30</b>
Embossing height for module 400	<b>25</b>
Module length	<b>min. 1070 max. 6110</b>
Weight	<b>~ 4,5 kg/m<sup>2</sup></b>
Length of an overlap when separating metal sheets	<b>20</b>
Roof angle	<b>&gt;9°</b>

**Symmetrical profile**

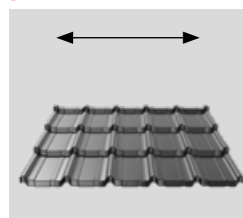

The design of FINN tiles allows for installation in any direction (left or right).

**3D shaped cut**



FINN roof tiles are wave-shape cut so that the horizontal joints of the sheets are less visible.

**Pre-punched mounting holes**

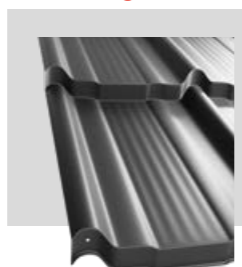

Pre-punched mounting holes on the vertical embossing enable the sheets to be fitted together quickly and tightly. Not only does it make installation easier, but it also speeds up the work considerably. Only for embossing height 30mm.

**Number of modules**

Module 350 mm	Module 400 mm	Number of modules
0,37	0,42	1
0,72	0,82	2
1,07	1,22	3
1,42	1,62	4
1,77	2,02	5
2,12	2,42	6
2,47	2,82	7
2,82	3,22	8
3,17	3,62	9
3,52	4,02	10
3,87	4,42	11
4,22	4,82	12
4,57	5,22	13
4,92	5,62	14
5,27	6,02	15
5,62	6,42	16
5,97	6,82	17
6,32	7,22	18
6,67		19
7,02		20
7,37		21





15/350  
15/400  
20/350  
20/400  
30/350  
35/350



You can find this product in our BP2 BIM library for architects and designers  
[www.bp2.eu/en/architects](http://www.bp2.eu/en/architects)

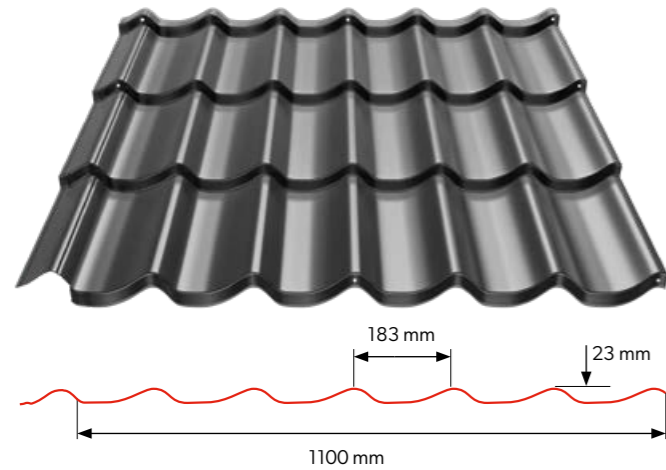

ALFA - Technical information [mm]	
Effective width	1100
Overall width	1183
Sheet thickness	0,5
Profile overall height	38/43/53/58
Embossing height for module 350	15/20/30/35
Embossing height for module 400	15/20
Module length	min. 1160 max. 6010
Weight	~ 4,5 kg/m <sup>2</sup>
Length of an overlap when separating metal sheets	60
Roof angle	>9°



25/350  
25/400  
30/350  
40/350



You can find this product in our BP2 BIM library for architects and designers  
[www.bp2.eu/en/architects](http://www.bp2.eu/en/architects)

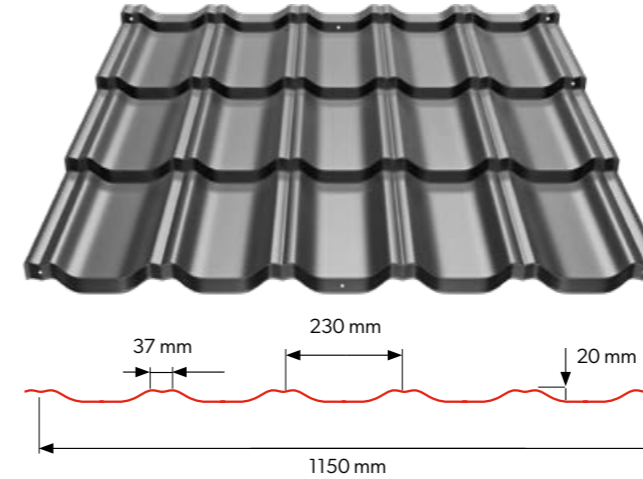

GAMMA - Technical information [mm]	
Effective width	1150
Overall width	1212
Sheet thickness	0,5
Profile overall height	45/50/60
Embossing height for module 350	25/30/40
Embossing height for module 400	25
Module length	min. 1160 max. 6110
Weight	~ 4,5 kg/m <sup>2</sup>
Length of an overlap when separating metal sheets	20
Roof angle	>9°

**EASY LINK**



A proprietary solution that makes the sheets fit together like never before. A special cut and profiling of the outermost embossing allow perfect fitting of the sheets at the point of contact.

**3D shaped cut**



ALFA roof tiles are wave-shape cut so that the horizontal joints of the sheets are less visible.

**Pre-punched mounting holes**



Pre-punched mounting holes on the vertical embossing enable the sheets to be fitted together quickly and tightly. Not only does it make installation easier, but it also speeds up the work considerably. Only for embossing height 30/40mm.

Number of modules		
Module 350 mm	Module 400 mm	Number of modules
0,41	0,46	1
0,76	0,86	2
1,11	1,26	3
1,46	1,66	4
1,81	2,06	5
2,16	2,46	6
2,51	2,86	7
2,86	3,26	8
3,21	3,66	9
3,56	4,06	10
3,91	4,46	11
4,26	4,86	12
4,61	5,26	13
4,96	5,66	14
5,31	6,06	15
5,66	6,46	16
6,01	6,86	17
6,36	7,26	18
6,71		19
7,06		20
7,41		21

**Symmetrical profile**

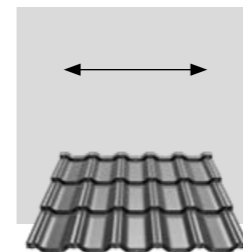

The design of GAMMA tiles allows for installation in any direction (left or right).

**3D shaped cut**



GAMMA roof tiles are wave-shape cut so that the horizontal joints of the sheets are less visible.

**Pre-punched mounting holes**

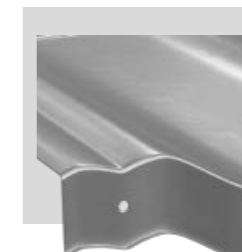

Pre-punched mounting holes on the vertical embossing enable the sheets to be fitted together quickly and tightly. Not only does it make installation easier, but it also speeds up the work considerably. Only for embossing height 30/40mm.

Number of modules		
Module 350 mm	Module 400 mm	Number of modules
0,37	0,42	1
0,72	0,82	2
1,07	1,22	3
1,42	1,62	4
1,77	2,02	5
2,12	2,42	6
2,47	2,82	7
2,82	3,22	8
3,17	3,62	9
3,52	4,02	10
3,87	4,42	11
4,22	4,82	12
4,57	5,22	13
4,92	5,62	14
5,27	6,02	15
5,62	6,42	16
5,97	6,82	17
6,32	7,22	18
6,67		19
7,02		20
7,37		21



25/350  
25/400  
30/350  
40/350



You can find this product in our BP2 BIM library for architects and designers  
[www.bp2.eu/en/architects](http://www.bp2.eu/en/architects)

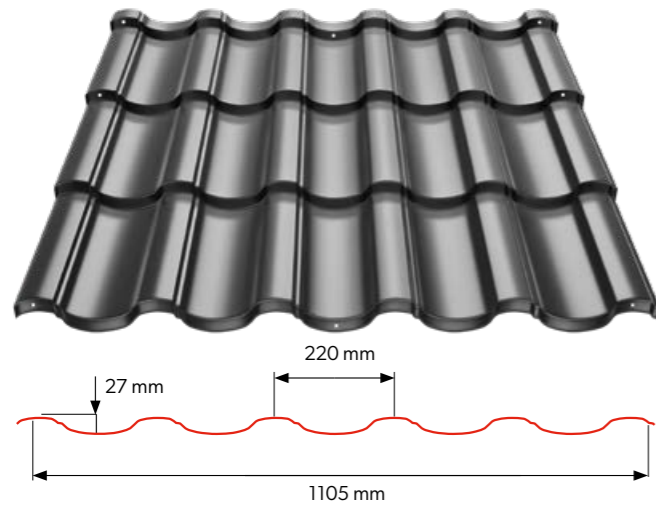

**STIGMA - Technical information [mm]**

Effective width	<b>1105</b>
Overall width	<b>1194</b>
Sheet thickness	<b>0,5</b>
Profile overall height	<b>52/57/67</b>
Embossing height for module 350	<b>25/30/40</b>
Embossing height for module 400	<b>25</b>
Module length	<b>min. 1160 max. 6110</b>
Weight	<b>~ 4,5 kg/m<sup>2</sup></b>
Length of an overlap when separating metal sheets	<b>20</b>
Roof angle	<b>&gt;9°</b>



25/350  
25/400  
30/350  
40/350



You can find this product in our BP2 BIM library for architects and designers  
[www.bp2.eu/en/architects](http://www.bp2.eu/en/architects)

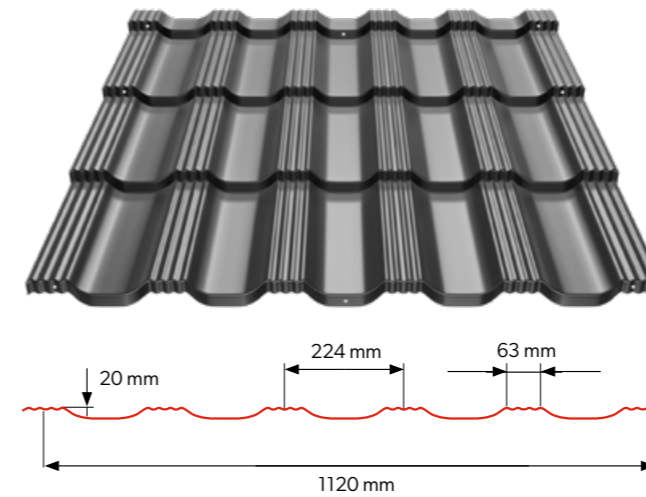

**BAVARIA Roof - Technical information [mm]**

Effective width	<b>1120</b>
Overall width	<b>1206</b>
Sheet thickness	<b>0,5</b>
Profile overall height	<b>45/50/60</b>
Embossing height for module 350	<b>25/30/40</b>
Embossing height for module 400	<b>25</b>
Module length	<b>min. 1160 max. 6110</b>
Weight	<b>~ 4,5 kg/m<sup>2</sup></b>
Length of an overlap when separating metal sheets	<b>20</b>
Roof angle	<b>&gt;9°</b>

**Symmetrical profile**

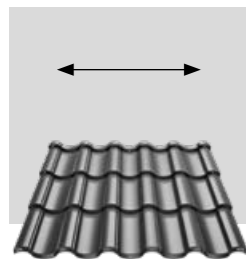

The design of STIGMA compact tiles allows for installation in any direction (left or right).

**3D shaped cut**



STIGMA roof tiles are wave-shape cut so that the horizontal joints of the sheets are less visible.

**Pre-punched mounting holes**



Pre-punched mounting holes on the vertical embossing enable the sheets to be fitted together quickly and tightly. Not only does it make installation easier, but it also speeds up the work considerably. Only for embossing height 30/40mm.

**Number of modules**

Module 350 mm	Module 400 mm	Number of modules
0,37	0,42	1
0,72	0,82	2
1,07	1,22	3
1,42	1,62	4
1,77	2,02	5
2,12	2,42	6
2,47	2,82	7
2,82	3,22	8
3,17	3,62	9
3,52	4,02	10
3,87	4,42	11
4,22	4,82	12
4,57	5,22	13
4,92	5,62	14
5,27	6,02	15
5,62	6,42	16
5,97	6,82	17
6,32	7,22	18
6,67		19
7,02		20
7,37		21

**Symmetrical profile**

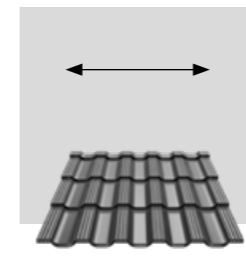

The design of BAVARIA Roof tiles allows for installation in any direction (left or right).

**3D shaped cut**



BAVARIA Roof tiles are wave-shape cut so that the horizontal joints of the sheets are less visible.

**Pre-punched mounting holes**

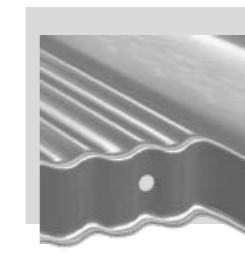

Pre-punched mounting holes on the vertical embossing enable the sheets to be fitted together quickly and tightly. Not only does it make installation easier, but it also speeds up the work considerably. Only for embossing height 30/40mm.

**Number of modules**

Module 350 mm	Module 400 mm	Number of modules
0,37	0,42	1
0,72	0,82	2
1,07	1,22	3
1,42	1,62	4
1,77	2,02	5
2,12	2,42	6
2,47	2,82	7
2,82	3,22	8
3,17	3,62	9
3,52	4,02	10
3,87	4,42	11
4,22	4,82	12
4,57	5,22	13
4,92	5,62	14
5,27	6,02	15
5,62	6,42	16
5,97	6,82	17
6,32	7,22	18
6,67		19
7,02		20
7,37		21



7

## RETRO SERIES

80. FINN RETRO

81. ALFA RETRO

82. GAMMA RETRO

84. STIGMA RETRO

85. BAVARIA Roof RETRO



RETRO SERIES is a line of cost-effective roof coverings in the form of sheets adapted to the roof design. The series consists of four tile profiles: FINN RETRO, ALFA RETRO, GAMMA RETRO and STIGMA RETRO.

RETRO SERIES tiles are cut-to-size sheets that perfectly match the roof design. The economy of the product makes it an excellent solution for large-scale constructions. The embossing height of the RETRO SERIES profiles is 15 mm and the module length is 350 mm. The RETRO SERIES roof tiles are characterised by an extended eaves cut. The overlap at sheet division is 110 mm.

The most important features of RETRO SERIES roof tiles:

- Classic steel roof tiles cut to size.
- Available in a wide range of colors and coating types.
- Extended cut at the eaves.





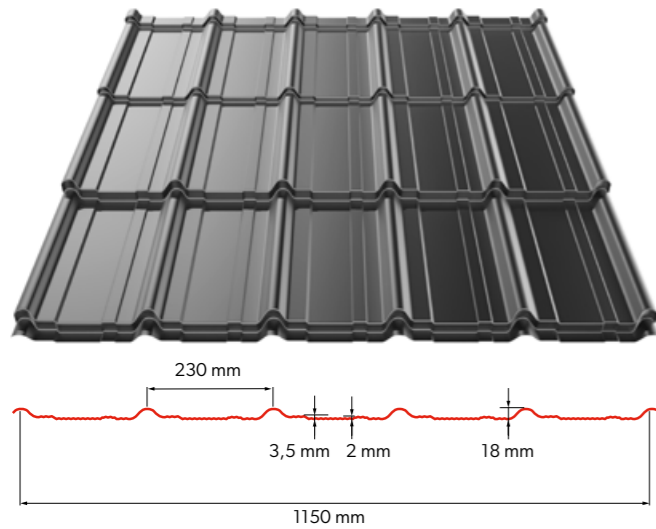

FINN RETRO - Technical information [mm]	
Effective width	1150
Overall width	1190
Sheet thickness	0,5
Height przetloczeni	15
Module length	min. 1700 max. 6110
Weight	~ 4,5 kg/m <sup>2</sup>
Length of an overlap when separating metal sheets	110
Roof angle	>9°

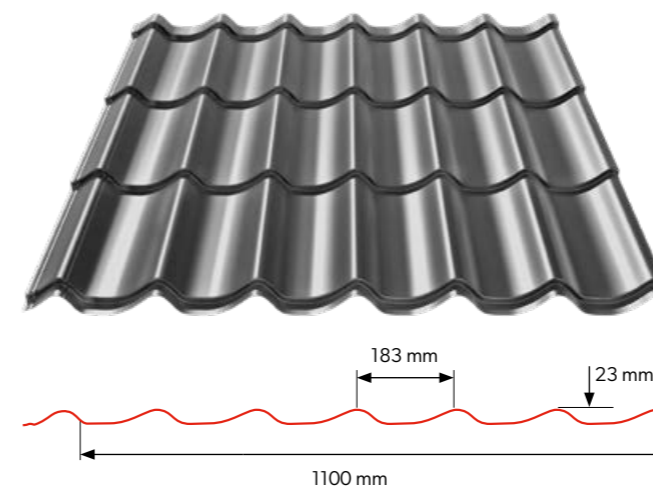

ALFA RETRO - Technical information [mm]	
Effective width	1100
Overall width	1183
Sheet thickness	0,5
Height przetloczeni	15
Module length	min. 1160 max. 6060
Weight	~ 4,5 kg/m <sup>2</sup>
Length of an overlap when separating metal sheets	110
Roof angle	>9°

OVERLAP

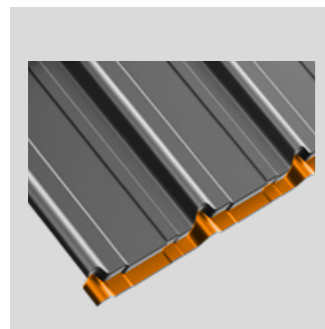

Symmetrical profile

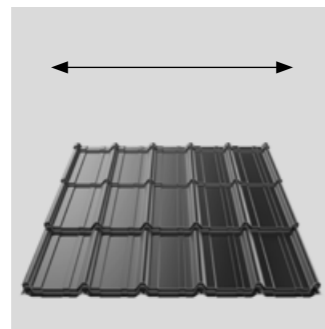

Number of modules	
Module 350 mm	Number of modules
0,46	1
0,81	2
1,16	3
1,51	4
1,86	5
2,21	6
2,56	7
2,91	8
3,26	9
3,61	10
3,96	11
4,31	12
4,66	13
5,01	14
5,36	15
5,71	16
6,06	17
6,41	18
6,76	19
7,11	20

OVERLAP

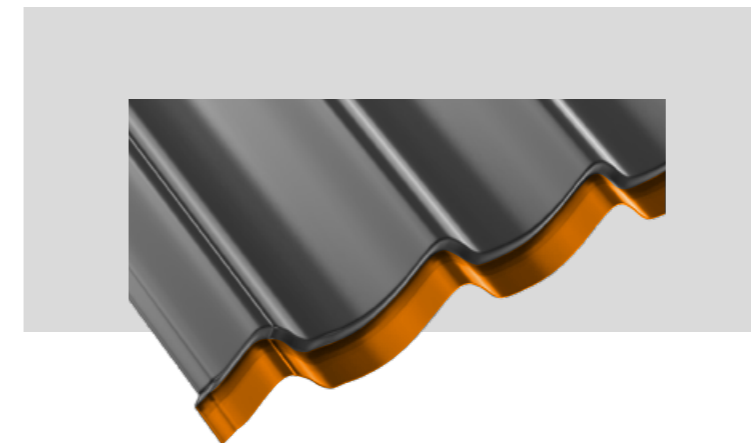

Number of modules	
Module 350 mm	Number of modules
0,46	1
0,81	2
1,16	3
1,51	4
1,86	5
2,21	6
2,56	7
2,91	8
3,26	9
3,61	10
3,96	11
4,31	12
4,66	13
5,01	14
5,36	15
5,71	16
6,06	17
6,41	18
6,76	19
7,11	20



You can find this product in our BP2 BIM library for architects and designers  
[www.bp2.eu/en/architects](http://www.bp2.eu/en/architects)



You can find this product in our BP2 BIM library for architects and designers  
[www.bp2.eu/en/architects](http://www.bp2.eu/en/architects)



# GAMMA RETRO

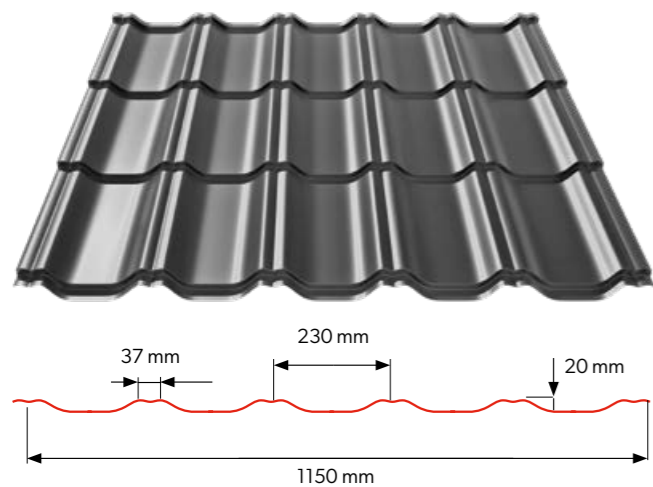

Technical information [mm]	
Effective width	1150
Overall width	1212
Sheet thickness	0,5
Embossing height	15
Module length	min. 1160 max. 6060
Weight	~ 4,5 kg/m <sup>2</sup>
Length of an overlap when separating metal sheets	110
Roof angle	>9°

## OVERLAP

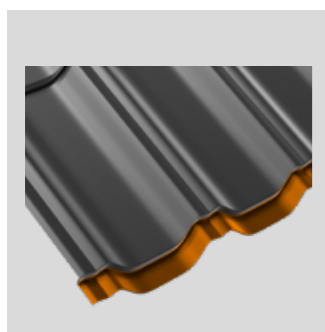

## Symmetrical profile

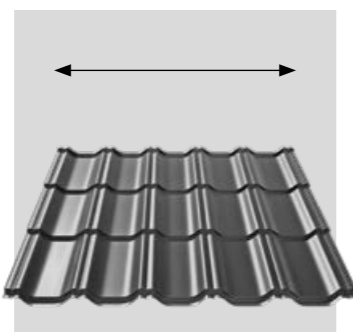

Number of modules	
Module 350 mm	Number of modules
0,46	1
0,81	2
1,16	3
1,51	4
1,86	5
2,21	6
2,56	7
2,91	8
3,26	9
3,61	10
3,96	11
4,31	12
4,66	13
5,01	14
5,36	15
5,71	16
6,06	17
6,41	18
6,76	19
7,11	20



You can find this product in our BP2 BIM library for architects and designers  
[www.bp2.eu/en/architects](http://www.bp2.eu/en/architects)



# STIGMA RETRO

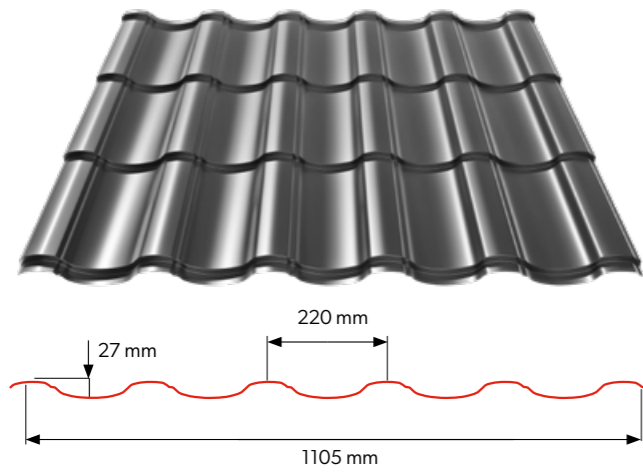

Technical information [mm]	
Effective width	1105
Overall width	1194
Sheet thickness	0,5
Embossing height	15
Module length	min. 1160 max. 6060
Weight	~ 4,5 kg/m <sup>2</sup>
Length of an overlap when separating metal sheets	110
Roof angle	>9°

# BAVARIA ROOF RETRO

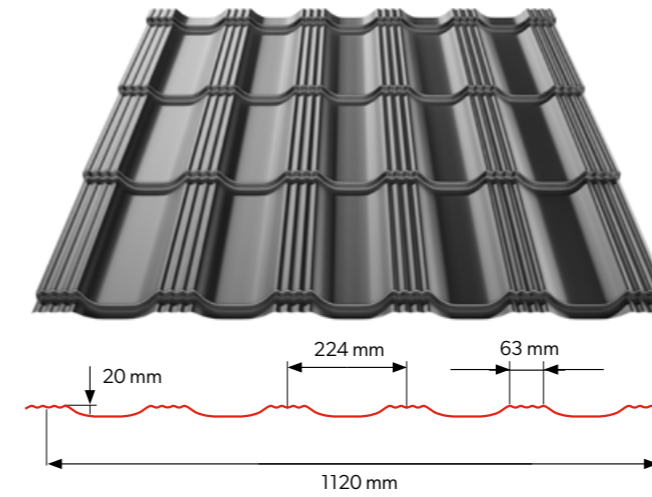

Technical information [mm]	
Effective width	1120
Overall width	1206
Sheet thickness	0,5
Embossing height	15
Module length	min. 1160 max. 6060
Weight	~ 4,5 kg/m <sup>2</sup>
Length of an overlap when separating metal sheets	110
Roof angle	>9°

## OVERLAP

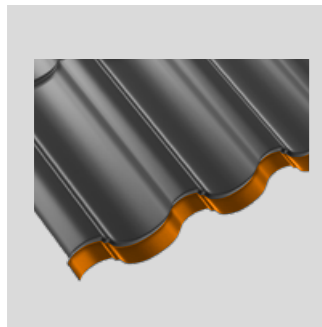

## Symmetrical profile

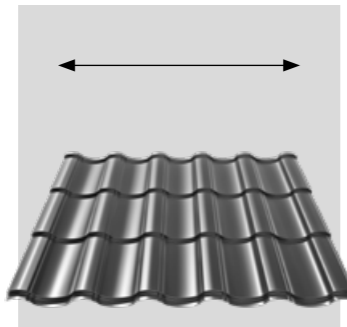

Number of modules	
Module 350 mm	Number of modules
0,46	1
0,81	2
1,16	3
1,51	4
1,86	5
2,21	6
2,56	7
2,91	8
3,26	9
3,61	10
3,96	11
4,31	12
4,66	13
5,01	14
5,36	15
5,71	16
6,06	17
6,41	18
6,76	19
7,11	20

## OVERLAP

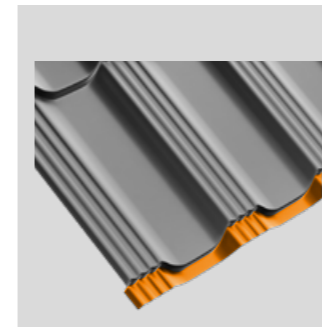

## Symmetrical profile

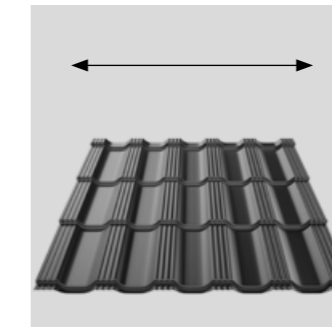

Number of modules	
Module 350 mm	Number of modules
0,46	1
0,81	2
1,16	3
1,51	4
1,86	5
2,21	6
2,56	7
2,91	8
3,26	9
3,61	10
3,96	11
4,31	12
4,66	13
5,01	14
5,36	15
5,71	16
6,06	17
6,41	18
6,76	19
7,11	20



You can find this product in our BP2 BIM library for architects and designers  
[www.bp2.eu/en/architects](http://www.bp2.eu/en/architects)



You can find this product in our BP2 BIM library for architects and designers  
[www.bp2.eu/en/architects](http://www.bp2.eu/en/architects)





# 8.

## Steel gutter system **INGURI**

88. Technical information

89. Description of elements

90. Advantages of INGURI

94. Colours

95. Feedstock



## Technical information

The use of a proper gutter system allows efficient drainage of water from the roof covering which is crucial for its durability and functionality. It also protects the façade of the building from damage caused by moisture.

INGURI 125/87 and 150/100 systems are complete gutter systems, manufactured from top quality steel coated on both sides. All system components have been designed to ensure correct fit and easy and quick installation.

The shape and depth of the gutters ensure effective water drainage even during heavy and prolonged rainfall.



## Description of elements

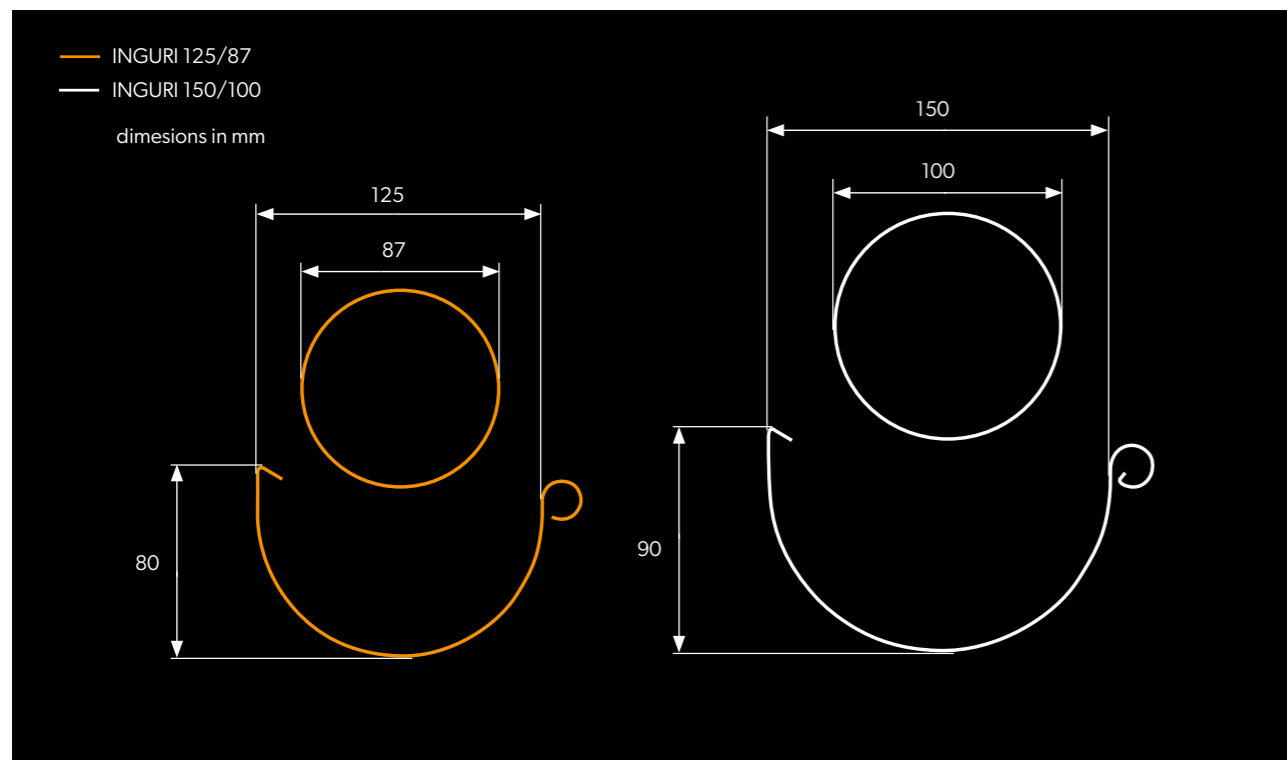

1	Gutter
2	Gutter support
3	Inner corner
4	Outer corner
5	Corner cover
6	Gutter fasteners
7	Fastener stabilizer
8	Gutter end cap
9	Gutter outlet
10	Drain pipe elbow
11	Drain pipe
12	Tee pipe
13	Cleanout
14	Spout
15	Sleeve
16	Drain pipe clamp half
17	Screw clamp
18	Dowels for screw clamp
19	Top rafter hooks
20	Face hook

# Advantages of INGURI steel gutter system



## PROTECTION OF YOUR HOME

Using the right gutter system allows water to be efficiently drained from the roofing material which is crucial to its durability and functionality. It also protects the facade of the building from the effects caused by moisture. Gutter system INGURI 125/87 and 150/100 is a complete system produced from the highest quality organic coated steel or metallic coating Aluzinc. This system will effectively protect your home.



## RELIABLE TIGHTNESS

The joint with the stabilizer is equipped with a gasket that ensures the tightness of the system even under extreme weather conditions. Complementary to the gutter is a bottom, equipped with gaskets, with the possibility of riveting and screwing.



## EXCELLENT WATER DRAINAGE

INGURI gutters are much deeper than competitive products, this design prevents the phenomenon of overflow of water outside the gutter, which occurs during heavy rainfall. Ergonomic gutters protect the facade against stains.



## HIGH RESISTANCE TO WEATHER CONDITIONS

Used for the manufacture of INGURI gutter systems sheet metal with a thickness of 0.6 mm is coated with an organic layer. The coating has a very high resistance to atmospheric factors and mechanical damage and influence of sun rays (UV) responsible for loss of color. INGURI systems are also produced from Aluzinc 185 sheets with an additional Easyfilm polymer coating on both sides.



## PEACE OF MIND FOR YEARS

INGURI system is covered by 30-years manufacturer warranty. Such a long warranty period is ensured by high quality of the input material and many years of experience of the manufacturer. By using materials with the highest technical parameters, we give our customers a product that provides peace of mind for years.



## SIMPLE INSTALLATION

INGURI system consists of perfectly matching elements thanks to which installation is easy and quick.



## INGURI ON THE MOVE

The long pieces are protected with a special foil sleeve so that the delivered material remains flawless. The gutters are transported in a specially equipped vehicle with balcony systems to warranty the safety of the material.



## WIDE RANGE OF COLORS

The offer of a complete gutter system INGURI includes a wide range of colors that allow the gutter system to put the finishing touches to the roof. The right choice of gutter system guarantees a flawless effect of the investment and harmony.



## COMPLETE OFFER

When you buy a complete roofing with gutter system INGURI, you get a longer warranty.

- \* 30 years ULTIMAT [UTK] coating.
- \* 40 years HERCULIT [HC] coating.



GUTTER

The shape of INGURI gutters is specially designed to ensure high efficiency in draining water. They have great depth and the proper profile to effectively collect water from the roof slope even during heavy rainfall without the risk of overflow. We manufacture gutters in standard lengths of 4 and 3 m.



GUTTER FASTENER

The individual sections of the gutter or the gutter with the corner are connected by means of a dedicated fastener. INGURI systems are equipped with a clip fastener (snap mechanism) to ensure a strong and durable joint with quick and easy installation. The standard fitting of the fastener with a gasket guarantees a tight connection while the execution of the element of sheet metal of the same colour as the remaining parts of the system ensures high aesthetics. The fastener is equipped with a stabiliser as standard, which additionally stiffens the joint.



INNER/OUTER CORNER

Aesthetic and functional connection of gutters in the corners of the building is ensured by gutter corners. Our range includes outer and inner corners with a standard 90° angle as well as 135° versions.



TEE PIPE

If it is necessary to discharge water from two drain pipes into one spout, a tee pipe should be used.



DRAIN PIPE

INGURI system drain pipes have a cross-section of 87 and 100 mm. Standard pipe lengths are 3m and 1m. Fixing to the façade is carried out using dedicated clamps to ensure adequate distance from the building wall.



GUTTER END CAP

A component used to close the gutter at its ends. The offered cap has a large depth and is additionally equipped with a gasket.



PIPE CLAMP / SCREW CLAMP

We offer two types of clamps: those with mounting holes for any type of fastener and those adapted for a dedicated connector.



TOP RAFTER HOOK

The top rafter hook is mounted directly to the rafters of the roof.



FACE HOOK

The face hook is a gutter fixing element mounted to the eaves fascia board.



SLEEVE

Drain pipes are connected by means of a sleeve. The precise manufacture of this element means that there is no risk of leakage at the joint.

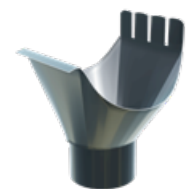

DRAIN PIPE

The drain pipe collects water from the gutters and directs it to the spout. The design and proper installation of this element greatly affects the functionality of the entire drainage system. The gutter drain of the INGURI systems is very well matched to the other components, ensuring a tight and solid installation. Available versions: 125/87, 125/100, 150/100.



SPOUT

The starting element of a gutter system is the spout, which carries the water away from the drain pipe. The product on offer has an angle of 63° and a section of 87 or 100 mm."



CLEANOUT

This element stops and enables the removal of debris falling into the drain pipe together with the water, such as leaves, feathers and small branches. This helps to maintain the system's patency and, as a result, its full functionality.



DOWELS FOR SCREWED CLAMPS

We supply dowels for clamps in three lengths: 160, 250 and 300mm.



CORNER COVER

The cover prevents water from overflowing through the corner. This is particularly important if it is fitted to an inner corner that receives large amounts of water from the valley gutter. It also has an ornamental role.



DRAIN PIPE ELBOW

It allows the system components to be adapted to different roof and façade shapes. The offered product is bent at an angle of 63°."



GUTTER SUPPORT

An element for additional fixing of the gutter to the roof structure. It prevents deformation or breakage of the gutter as a result of heavy loads, e.g. due to snow sliding off the roof.

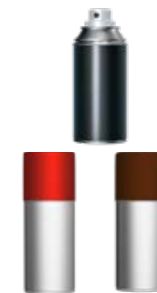

ACCESSORIES

We ensure the availability of accessories for gutter systems: gliding spray, silicones and touch-up paint.

# Colours

## INGURI

INGURI gutters are manufactured from hot-dip galvanised sheet metal which, after chemical cleaning and passivation, is coated with a multi-layer anticorrosive and decorative organic coating. The thickness of the sheet is 0.6 mm while the organic layer is a material with very high resistance to weathering, mechanical damage, and the effects of solar radiation (UV) responsible for the loss of colour.

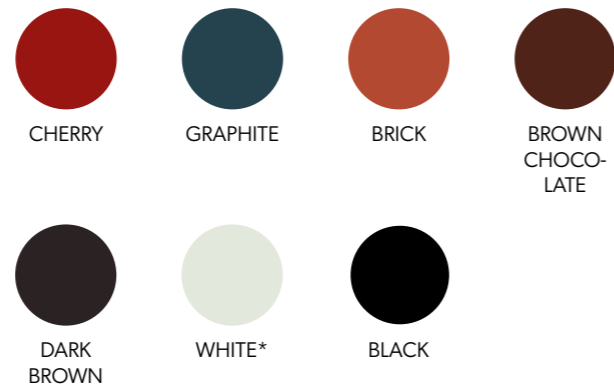

Paint coating thickness	Zinc coating thickness	Corrosion resistance	UV resistance	Warranty period (years)
50 µm	275 g/m <sup>2</sup>	RC4	RUV3	30

## Aluzinc INGURI [AZ 185]

It is a steel sheet coated on both sides with an aluminium-zinc alloy in a process similar to hot-dip galvanizing. Thanks to this, it meets the strictest requirements for sheet resistance to atmospheric corrosion and corrosion in humid environments. It also has a protective Easyfilm polymer coating."



Coating thickness	Corrosion resistance	UV resistance	Warranty period (years)
185 g/m <sup>2</sup>	RC3	n/a	15

! \* The white colour is only available for the INGURI 150/100 system.

! Printing technology does not allow for faithful colour rendition, so the colours shown are approximate and may differ from actual colours.

! Detailed warranty conditions are specified in the warranty certificate.

# Feedstock

The suppliers of material for the manufacture of INGURI gutters are renowned steel corporations, providing the highest quality steel in the form of Aluzinc sheets - galvanised and coated - which are the input material for the manufacture of gutters.

Careful selection of the feedstock supplier has a major impact on the quality and durability of the product. This is expressed by its resistance to corrosion and discolouration.

This is why INGURI gutter systems are covered by a long-term warranty.

## Coated sheet cross-section

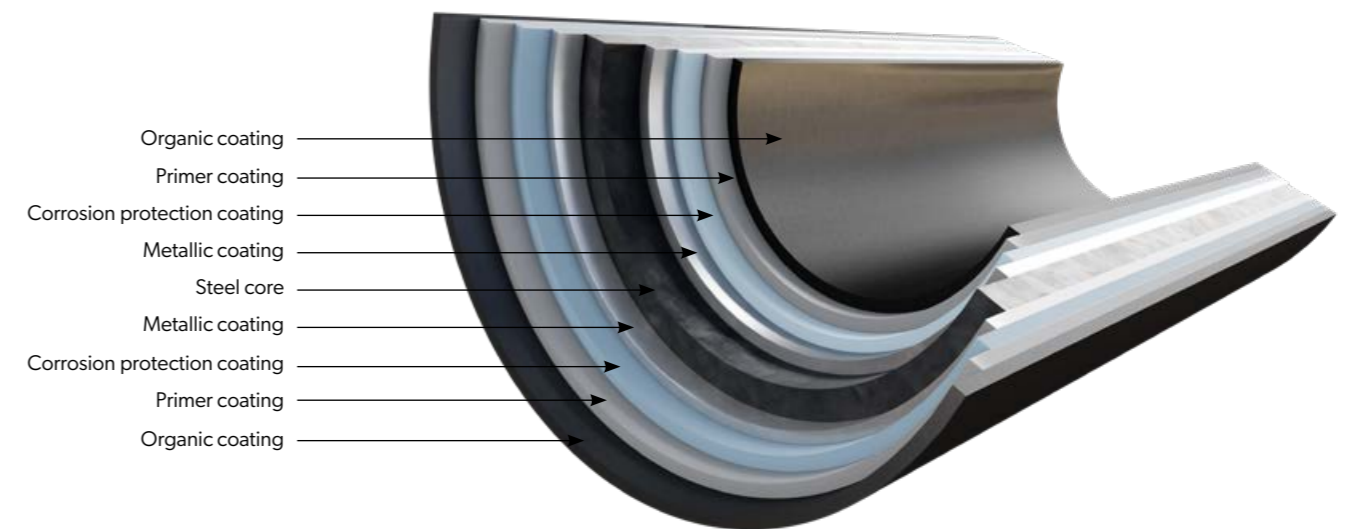

## Aluzinc sheet cross-section

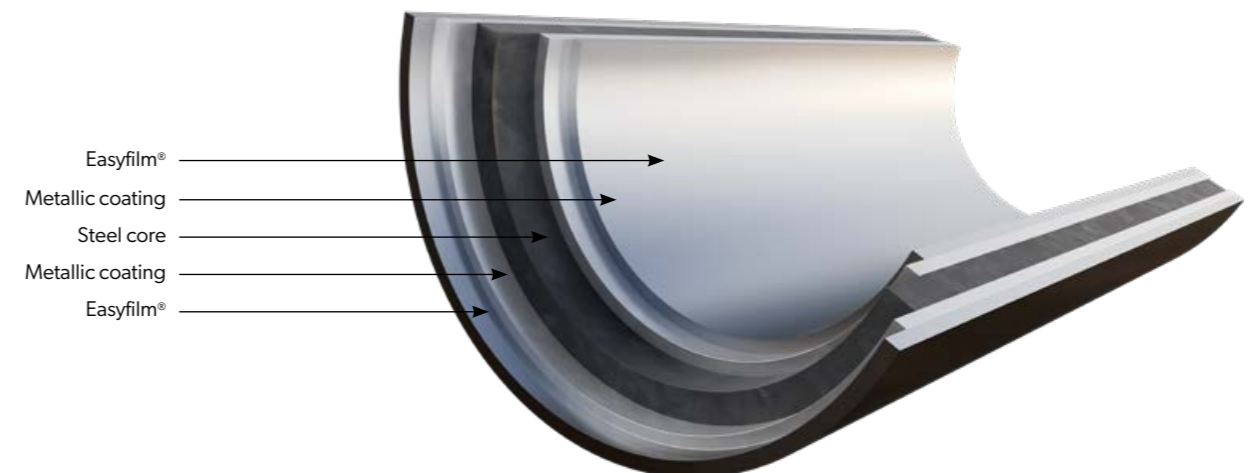





# 9.

## Flashings & accessories

98. New flashings

100. Flashings

104. Accessories

# New flashings



**Wind Brace ADAPT**  
- NEW

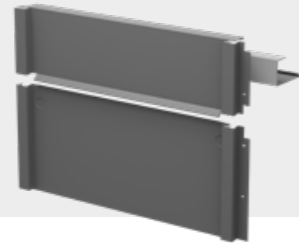

Sheet thickness	<b>0.5 mm</b>
Width	<b>550 mm</b>
Height	<b>240-320 mm</b>



**Wind Brace ADAPT**  
- NEW

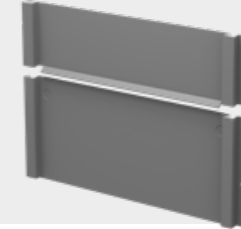

Sheet thickness	<b>0.5 mm</b>
Width	<b>550 mm</b>
Height	<b>240-320 mm</b>



**Wind Brace III**  
- NEW

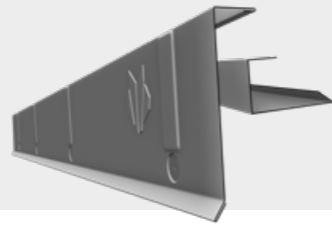

Sheet thickness	<b>0.5 mm</b>
Width	<b>2000 mm</b>
Height	<b>150 mm</b>



**Wind Brace II**  
- NEW

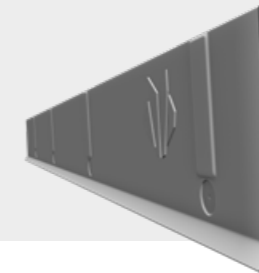

Sheet thickness	<b>0.5 mm</b>
Width	<b>2000 mm</b>
Height	<b>150 mm</b>



**Wind Brace II**  
- NEW

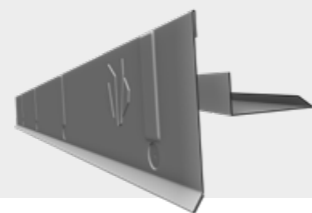

Sheet thickness	<b>0.5 mm</b>
Width	<b>2000 mm</b>
Height	<b>150 mm</b>



**AIR ridge tile**  
- NEW



Sheet thickness	<b>0.5 mm</b>
Width	<b>1088 mm</b>
Height	<b>85 mm</b>



**Valley gutter**  
- NEW

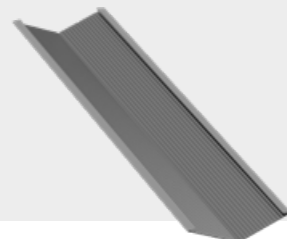

Sheet thickness	<b>0.5 mm</b>
Width	<b>2000 mm</b>
Height	<b>95 mm</b>



**Valley gutter**  
- NEW

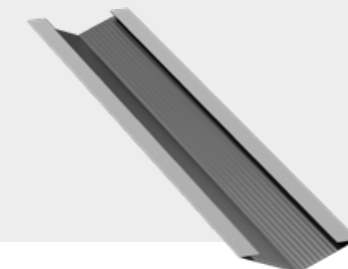

Sheet thickness	<b>0.5 mm</b>
Width	<b>2000 mm</b>
Height	<b>95 mm</b>

# Flashings



Ridge tile IZI

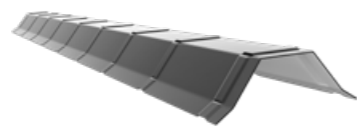

Sheet thickness	<b>0.5 mm</b>
Width	<b>2000 mm</b>
Height	<b>75 mm</b>

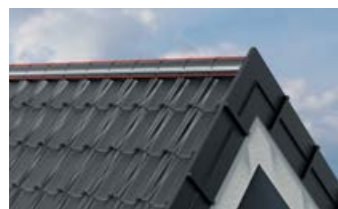

Ridge tile ZET

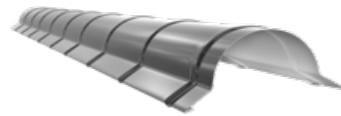

Sheet thickness	<b>0.5 mm</b>
Width	<b>1950 mm</b>
Height	<b>75 mm</b>



Ridge tile end



Sheet thickness	<b>0.5 mm</b>
Width	<b>220 mm</b>
Height	<b>80 mm</b>



Trapezoidal ridge tile



Sheet thickness	<b>0.5 mm</b>
Width	<b>2000 mm</b>
Height	<b>90 mm</b>



Barrel ridge tile

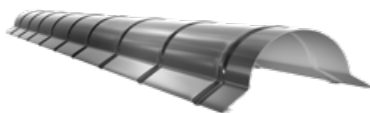

Sheet thickness	<b>0.5 mm</b>
Width	<b>2000 mm</b>
Height	<b>75 mm</b>



Wide barrel ridge tile

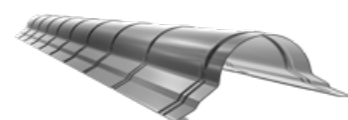

Sheet thickness	<b>0.5 mm</b>
Width	<b>2000 mm</b>
Height	<b>109 mm</b>



Starting drip-edge flashing for the gutter

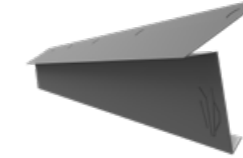

Sheet thickness	<b>0.5 mm</b>
Width	<b>2000 mm</b>
Height	<b>155 mm</b>

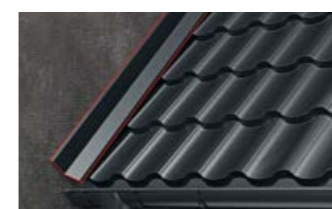

Wall flashing I

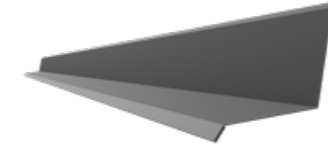

Sheet thickness	<b>0.5 mm</b>
Width	<b>2000 mm</b>
Height	<b>125 mm</b>

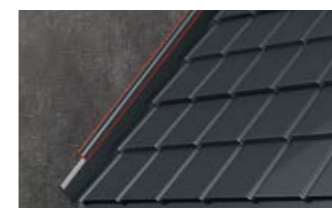

Expansion strip



Sheet thickness	<b>0.5 mm</b>
Width	<b>2000 mm</b>
Height	<b>65 mm</b>



Wall flashing with an expansion strip

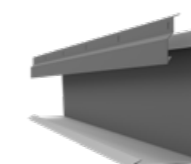

Sheet thickness	<b>0.5 mm</b>
Width	<b>2000 mm</b>
Height	<b>135 mm</b>



Universal ventilation flashing



Sheet thickness	<b>0.5 mm</b>
Width	<b>2000 mm</b>
Height	<b>26 mm</b>



Starting profile for ZET LOOK



Sheet thickness	<b>0.5 mm</b>
Width	<b>120 mm</b>
Height	<b>49 mm</b>

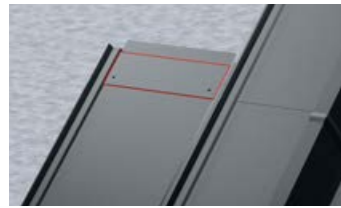

Roof panel connector

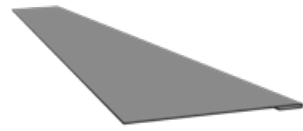

Sheet thickness	<b>0.5 mm</b>
Width	<b>500 mm</b>
Height	<b>120 mm</b>



Eaves strip



Sheet thickness	<b>0.5 mm</b>
Width	<b>2000 mm</b>
Height	<b>20 mm</b>



Drip edge

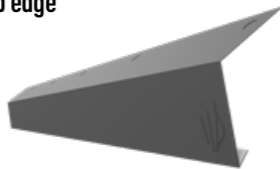

Sheet thickness	<b>0.5 mm</b>
Width	<b>2000 mm</b>
Height	<b>120 mm</b>



Universal verge trim / wind brace extension

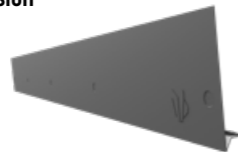

Sheet thickness	<b>0.5 mm</b>
Width	<b>2000 mm</b>
Height	<b>190 mm</b>

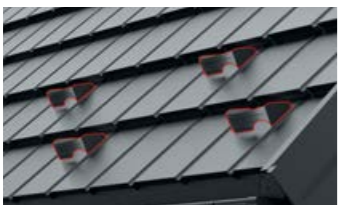

Snow guard



Sheet thickness	<b>0.5 mm</b>
Width	<b>196 mm</b>
Height	<b>70 mm</b>

BP2 Brand is continuously developing and tailoring their products to the needs of their customers. Hence, we have updated our flashings offer that saves installation time on the roof and ensures solid execution as well as highest aesthetics. Their professional installation is the key to the success of roofing details crafted with diligence.



BP2 - Flashings, details, advantages, dimensions.  
Scan the code and learn more.



# Clamping systems



**Farmer Screws** - Self-drilling screws with EPDM washer for Clamping systems of sheet metal, tin roofing and flashings to wood substrate. Farmer type screw with TX socket.



**Farmer Screws** - Self-drilling screws with EPDM washer for Clamping systems of sheet metal, tin roofing and flashings to wood substrate. Farmer type screw.



**Self-drilling screws** - Self-drilling screw for Clamping systems thin sheets overlapping.



**Clamping screws** - Self-tapping screw for Clamping systems of steel elements to profiles and overlapping connection of steel elements.



**Sandwich panel screws** - Self-drilling screw with EPDM aluminum washer for Clamping systems of sandwich panels to steel substrate.

CLAMPING SYSTEMS	Dimensions	unit
	[mm]	
Farmer Screws	4,8 x 19	250 pcs
Farmer Screws	4,8 x 35	250 pcs
Farmer Screws	4,8 x 55	200 pcs
Farmer Screws TORX	4,8 x 35	250 pcs
Self-drilling screws max. 3,0 mm	4,8 x 19	250 pcs
Self-drilling screws max. 5,0 mm *	5,5 x 25	250 pcs
Self-drilling screws max. 12,0 mm *	5,5 x 32	250 pcs
Clamping screws L	4,2 x 32	500 pcs

\* Product available on request.

# Roof communication systems



**Roof Chimney sweep bench - Chimney sweep bench.** With a large, non-slip surface. Available in lengths from 0,4 to 3,0 m. Safe width - 250 mm.systems



**Chimney step - Roof step** is one of the components of the communication system on the sloping roof. It consists of a solid mounting part, a non-slip surface for the footing and a handle.



**Snow fence - Snow fence system** is a stable and effective solution to protect against sliding from the roof masses of snow.

ROOF COMUNICATION SYSTEMS	unit
Snow fence 2,0 m	pcs
Snow fence pipe LAMBDA 2.0 / IZI 2,0 m	set
Snow fence bracket for trapezoidal metal sheets	pcs
Snow fence bracket for metal roofing tiles	pcs
Fence bracket for IZI modular tiles	pcs
Chimney sweep bench 0.40 m	pcs
Chimney sweep bench 0.60 m	pcs
Chimney sweep bench 0,80 m	pcs
Chimney sweep bench 1,00 m	pcs
Chimney sweep bench 2,0 m	pcs
Chimney sweep bench 3,0 m	pcs
Step bracket	pcs
Bench/footing bracket for trapezoidal sheet metal	pcs
Bench/footing bracket for tin plates	pcs
Step for chimney sweep	pcs
Wall bench bracket	pcs
Step bracket	pcs

## Seal systems and ventilation chimneys



**Profiled gasket** - Profiles shaped to mimic the corresponding roofing profile with holes are designed to protect gaps in roofs.



**Ridge Tape** - Vapor-permeable ridge tape is used to seal and ventilate the ridge.



**Roofing silicone** - Plastic-flexible, one-component rubber roofing putty for sealing flashing.



**Vent stack** - Vent chimneys are used as an element that terminates the gravity ventilation line in buildings - they are an alternative to masonry ventilation chimneys.

SEAL SYSTEMS AND VENTILATION CHIMNEYS	Dimensions	unit
	[mm]	
Profile gasket. ALFA, T14, T18, T18 ECO ridge	~ 1000	pcs
Profile gasket. ALFA, T14, T18, T18 ECO set	~ 1000	set
Profile gasket. STIGMA, GAMMA/ZET, BAVARIA ridge profile gasket	~ 1000	pcs
Profile gasket. STIGME, GAMMA/ZET, BAVARIA set	~ 1000	set
Profile gasket. T35, T35 ECO, T55, T60 ridge	~ 1000	pcs
Profile gasket. T35, T35 ECO, T50, T55 set	~ 1000	set
Profile gasket. T60 set	~ 1000	set
Wedge seal	1000	pcs
Wedge seal - expanding PURS	1000	pcs
ALU ridge tape	240 mm x 5 mb	mb
Roofing silicone	280 ml	pcs
Ventilation chimney for tile, ZET - uninsulated	Ø 125	pcs
Ventilation chimney for tile roof, ZET - insulated	Ø 125	pcs
Ventilation chimney for trapezoidal sheet metal - uninsulated	Ø 125	pcs
Ventilation chimney for trapezoidal sheet metal - insulated	Ø 125	pcs
Ventilation chimney for IZI modular roofing tile	Ø 110	pcs

## Foils, membranes, lacquers and skylights



**Membranes** - Roof membranes are used as a layer of initial covering under sloped roofing. They prevent precipitation suspended there from getting into the thermal insulation and roof structure: rain and snow.



**Paints and varnishes** - Matching varnishes are used to protect cut edges and any damage to the covering film caused during installation.

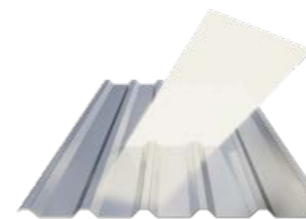

**Paints and Skylights** - Profiled polycarbonate sheets for roofing and walls. They are characterized by exceptional strength properties - excellent transparency, shape retention at high temperatures and impact resistance. - Matching varnishes are used to protect cut edges and any damage to the covering film caused during installation.

FOILS, MEMBRANES, LACQUERS AND SKYLIGHTS	Dimensions	unit
BP2 Protect 100 g membrane	1,6 m x 50 mb	m <sup>2</sup>
BP2 Protect 120 g membrane	1,6 m x 50 mb	m <sup>2</sup>
BP2 Protect membrane 140 g	1,6 m x 50 mb	m <sup>2</sup>
Roof screen - 265 g	1,6 m x 25 mb	m <sup>2</sup>
Spray-on touch-up paint	150 ml	pcs
Repair paint can	200 ml	pcs
Skylight T18 ECO Total width 1.169 m Length 3 m	3,507	m <sup>2</sup> c
Skylight T18 Overall width 1,117 m Length 3 m	3,351	m <sup>2</sup> c
Skylight T35 Overall width 1,105 m Length 3 m	3,315	m <sup>2</sup> c



# 10.

## Trapezoidal sheets

110. SINUS

112. T7, T14

113. T18, T18 ECO

114. T35, T35 ECO

115. T50, T55

116. T60, T80

117. T130, T135-930

118. T135-950, T153

119. T160, T200



# Corrugated sheet SINUS

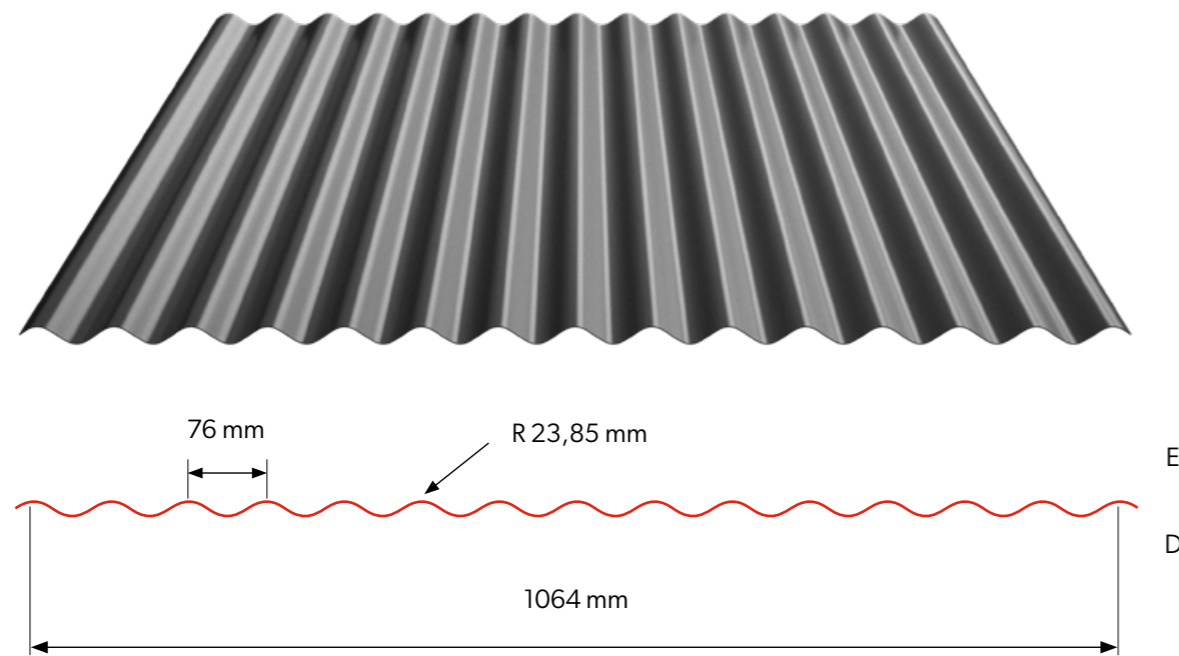

Technical information [mm]	
Effective width	1064
Total width	~1100
Profile height	18
Thickness	0,5-0,8
Max. sheet length	8000
Roof angle	> 6°



You can find this product in our BP2 BIM library for architects and designers [www.bp2.eu/en/architects](http://www.bp2.eu/en/architects)





# T7

Technical parameters [mm]	
Effective width	1177
Overall width	~1210
Profile height	7,0
Sheet thickness	0,5-1,0
Maximum sheet length	6000

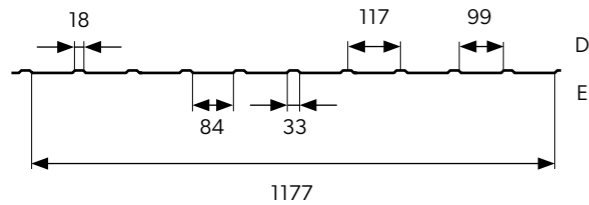
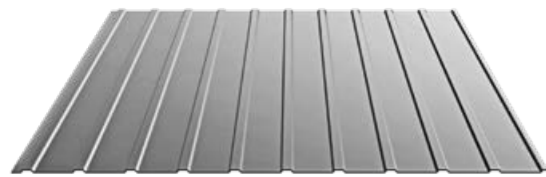

# T14

Technical parameters [mm]	
Effective width	1100
Overall width	~1161
Profile height	13
Sheet thickness	0,5-1,0
Maximum sheet length	8000

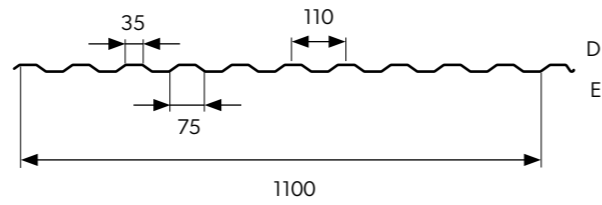
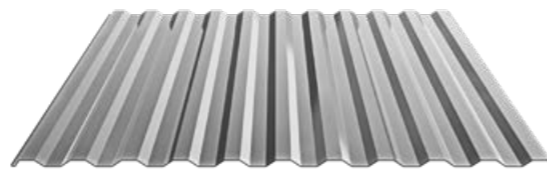

# T18

Technical parameters [mm]	
Effective width	1075
Overall width	~1125
Profile height	17
Sheet thickness	0,5-1,0
Maximum sheet length	12 000

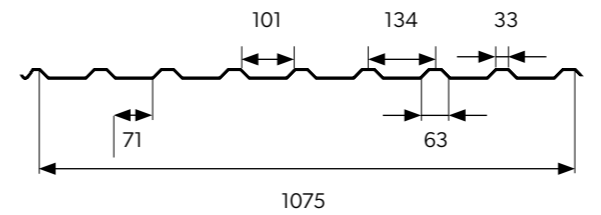
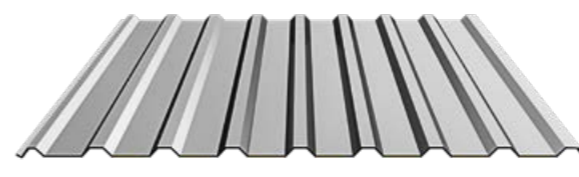

# T18 ECO

Technical parameters [mm]	
Effective width	1125
Overall width	~1173
Profile height	17
Sheet thickness	0,5-1,0
Maximum sheet length	12 000

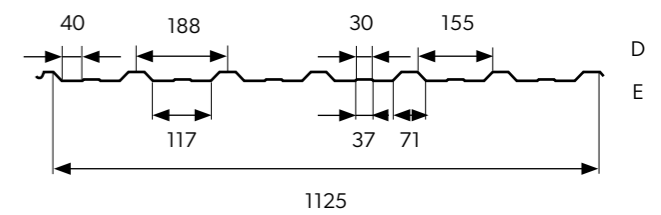
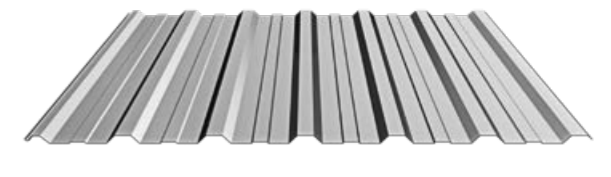

We offer perforation of trapezoidal sheets. Details (shape, size, hole pattern, etc.) are agreed individually with the sales department.  
**For more information, see page 168..**



You can find this product in our BP2 BIM library for architects and designers  
[www.bp2.eu/en/architects](http://www.bp2.eu/en/architects)



# T35

Technical parameters [mm]	
Effective width	1065
Overall width	~1106
Profile height	34
Sheet thickness	0,5-1,0
Maximum sheet length	12 000

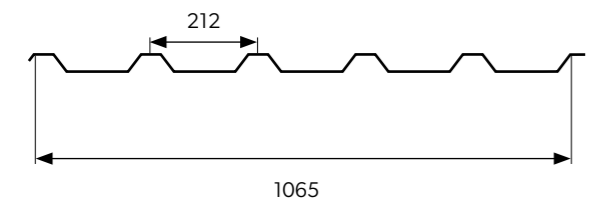
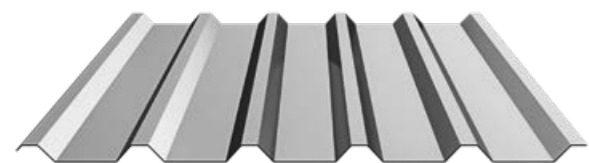

# T35 ECO

Technical parameters [mm]	
Effective width	1080
Overall width	~1120
Profile height	34
Sheet thickness	0,5-1,0
Maximum sheet length	12 000

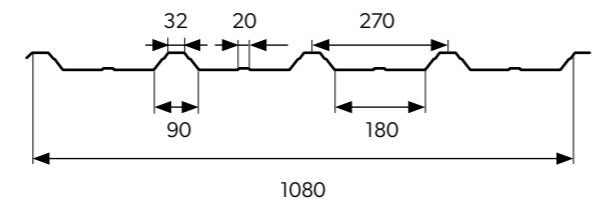
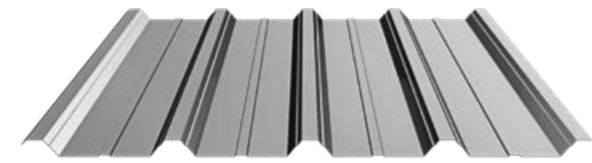

# T50

Technical parameters [mm]	
Effective width	1055
Overall width	~1100
Profile height	47
Sheet thickness	0,5-1,0
Maximum sheet length	12 000

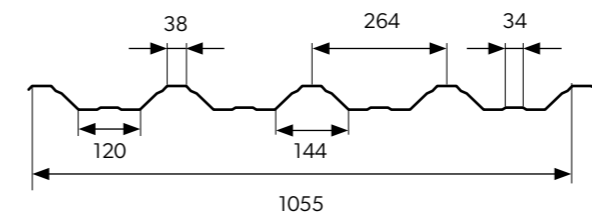
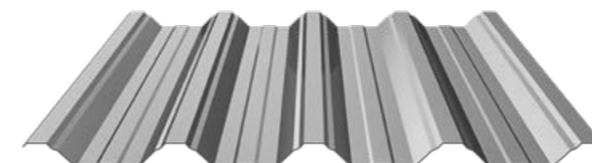

# T55

Technical parameters [mm]	
Effective width	1020
Overall width	~1054
Profile height	53
Sheet thickness	0,5-1,0
Maximum sheet length	12 000

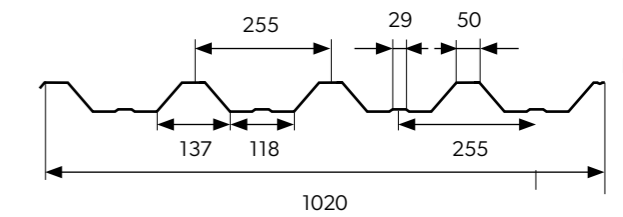
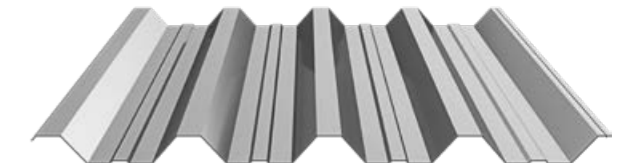

We offer perforation of trapezoidal sheets. Details (shape, size, hole pattern, etc.) are agreed individually with the sales department.  
**For more information, see page 168..**



You can find this product in our BP2 BIM library for architects and designers  
[www.bp2.eu/en/architects](http://www.bp2.eu/en/architects)



# T60

Technical parameters [mm]	
Effective width	1002
Overall width	~1040
Profile height	61
Sheet thickness	0,7-1,25
Maximum sheet length	12 000

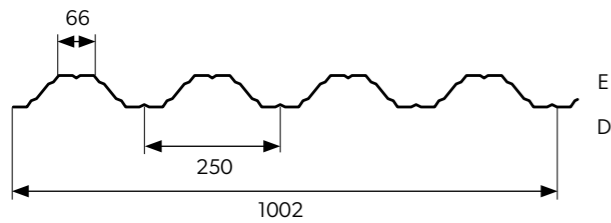
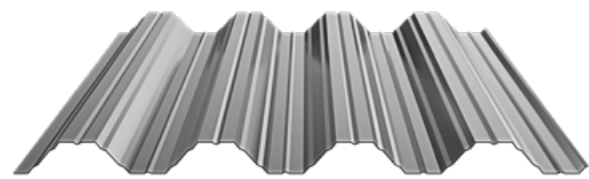

# T80

Technical parameters [mm]	
Effective width	1130
Overall width	~1165
Profile height	82
Sheet thickness	0,7-1,5
Maximum sheet length	14 000

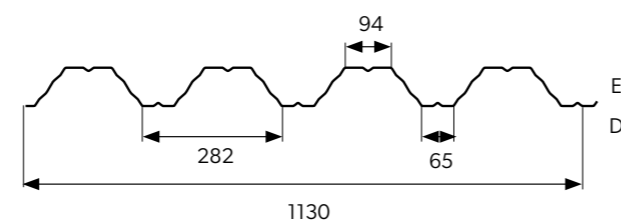
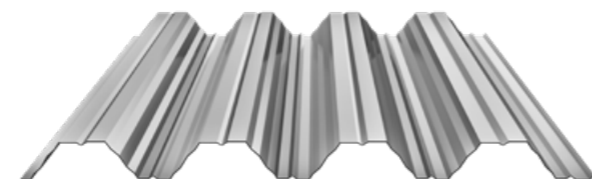

# T130

Technical parameters [mm]	
Effective width	1011
Overall width	1045
Profile height	134
Sheet thickness	0,7-1,5
Maximum sheet length	14 000

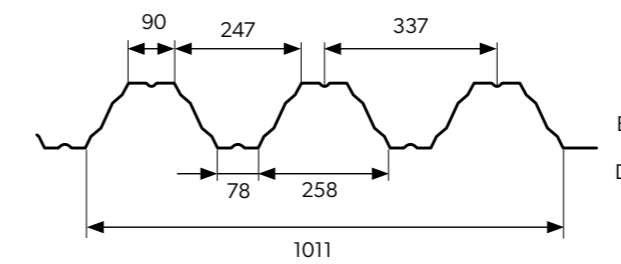
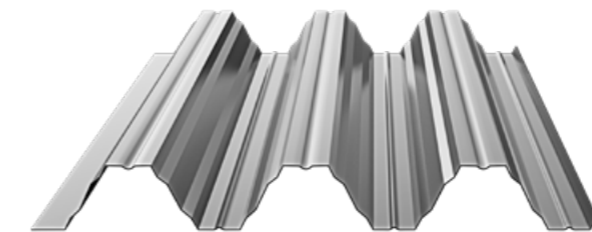

# T135-930

Technical parameters [mm]	
Effective width	930
Overall width	~974
Profile height	135
Sheet thickness	0,7-1,5
Maximum sheet length	14 000

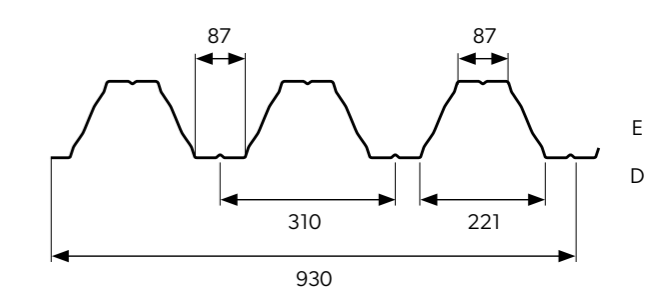
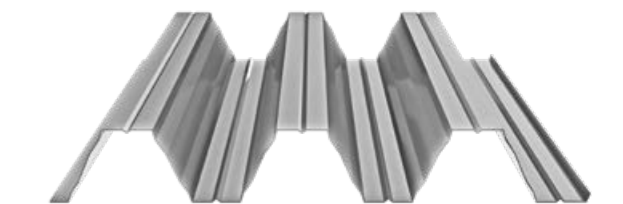

We offer perforation of trapezoidal sheets. Details (shape, size, hole pattern, etc.) are agreed individually with the sales department.  
**For more information, see page 168..**



You can find this product in our BP2 BIM library for architects and designers  
[www.bp2.eu/en/architects](http://www.bp2.eu/en/architects)



# T135-950

Technical parameters [mm]	
Effective width	950
Overall width	~994
Profile height	134
Sheet thickness	0,7-1,5
Maximum sheet length	14 000

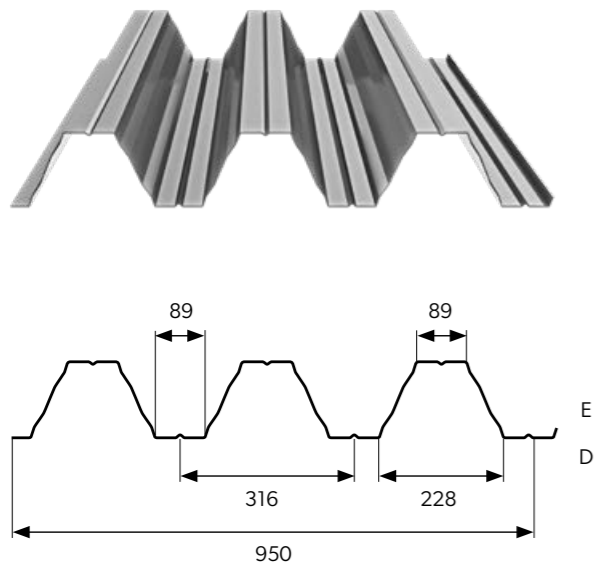

# T153

Technical parameters [mm]	
Effective width	840
Overall width	~880
Profile height	155
Sheet thickness	0,7-1,5
Maximum sheet length	14 000

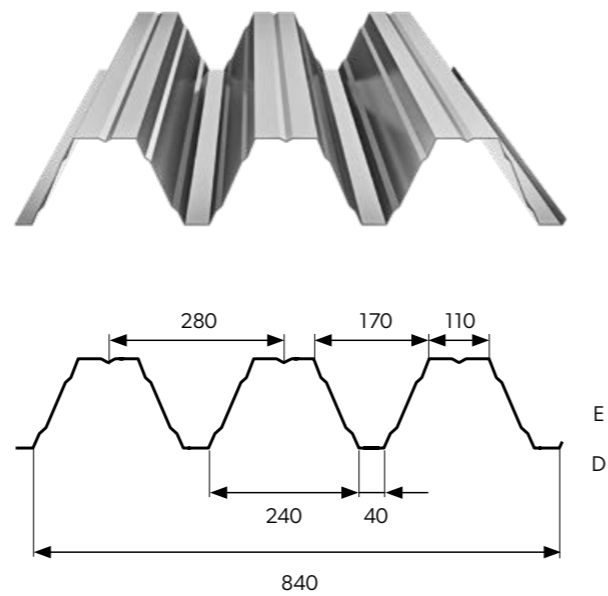

# T160

Technical parameters [mm]	
Effective width	750
Overall width	~790
Profile height	162
Sheet thickness	0,75-1,5
Maximum sheet length	14 000

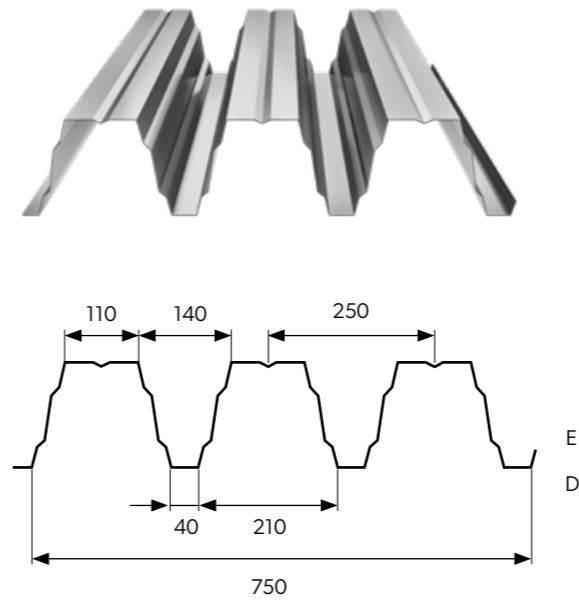

# T200

Technical parameters [mm]	
Effective width	840
Overall width	~883
Profile height	200
Sheet thickness	0,75-1,25
Maximum sheet length	15 000

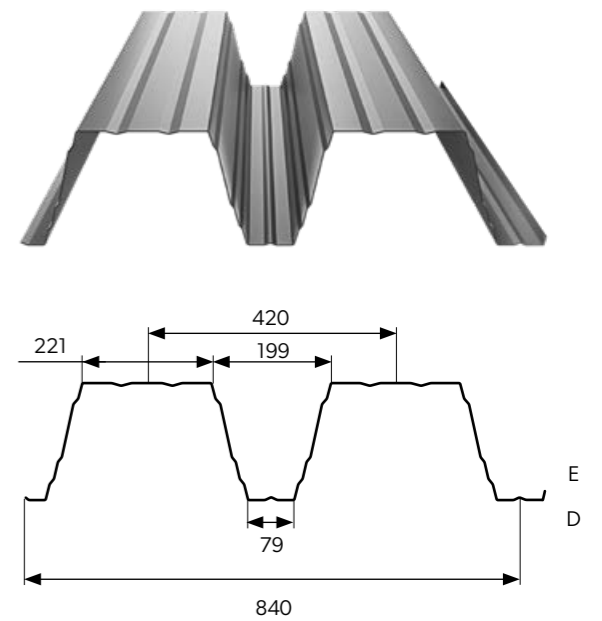

We offer perforation of trapezoidal sheets. Details (shape, size, hole pattern, etc.) are agreed individually with the sales department.  
**For more information, see page 168..**



You can find this product in our BP2 BIM library for architects and designers  
[www.bp2.eu/en/architects](http://www.bp2.eu/en/architects)





# 11.

## Liner tray & PROSYSTHERM

122. Liner tray

123. Installation

124. PROSYSTHERM 90 min fire rated wall

# Liner tray

Industrial buildings are subject to high fire resistance requirements and materials used must have high insulation properties. This is what liner trays are designed for.

Used as an internal component of façade systems, the product is mainly characterised by its quick and easy installation. Any external cladding can be used as the external finish (trapezoidal and corrugated sheet metal, LINEA cladding panel, SKRIN cladding cassette).

Technical parameters [mm]	
A	100
B	130
C	160
D	200

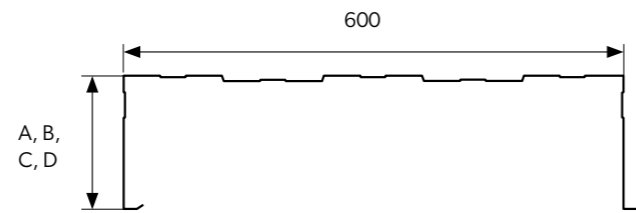

# Installation

The liner trays are mounted to the structural columns [1].

The fastener is selected according to the material of the columns [3].

Sealing tape is to be applied along the columns [2], on the front of the tray [5] and between the trays [6].

A 4.8x20 mm fastener [4] is used to stitch the vertically connected trays together.

When joining the tiles horizontally [7], a gap of ~1 cm must be maintained to allow the structure to work freely.

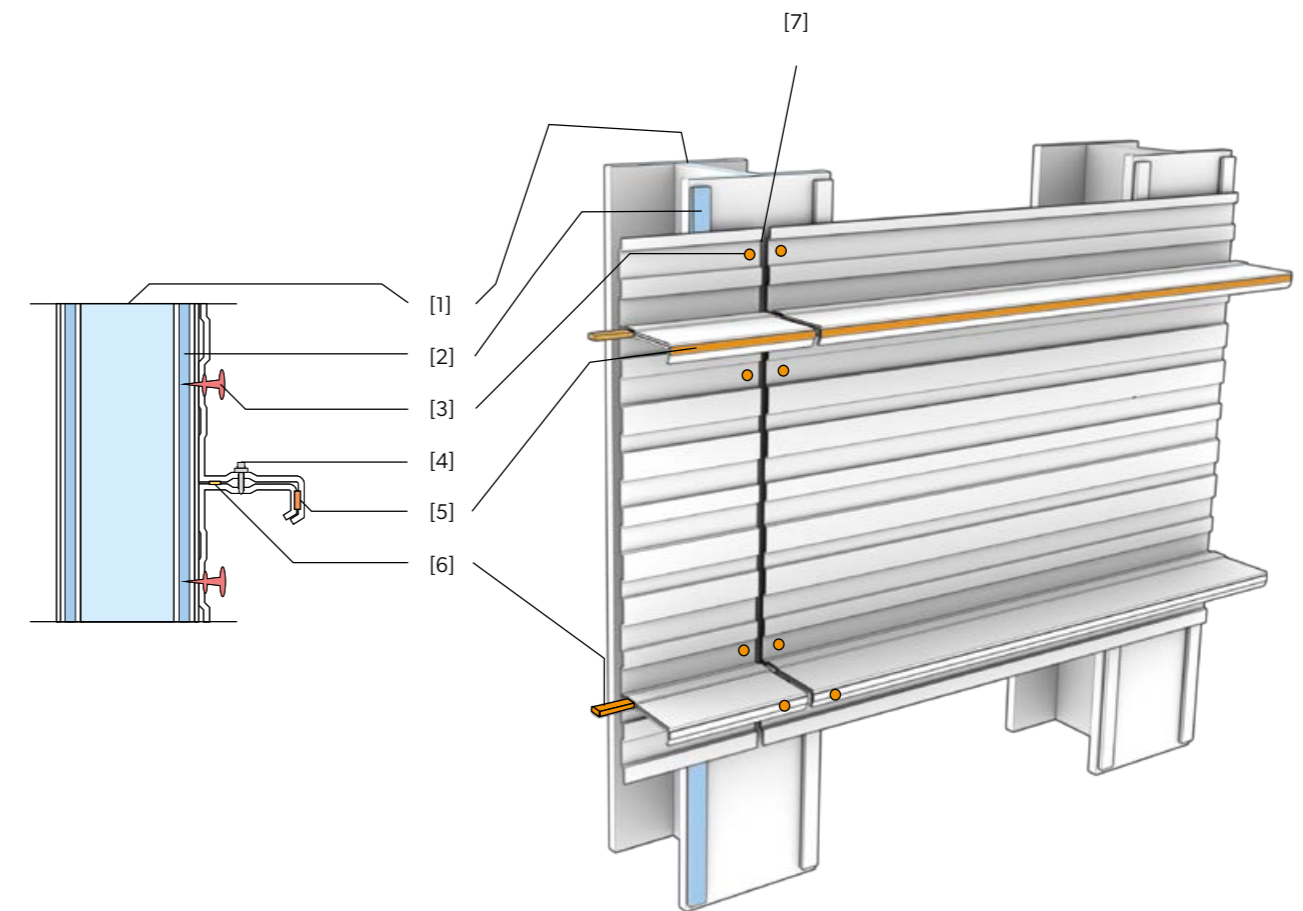

We offer perforation of liner trays. Details (shape, size, hole pattern, etc.) are agreed individually with the sales department.  
**For more information, see page 168..**

# PROSYSTHERM

## 90 min fire rated wall

The PROSYSTHERM wall offered by BP2 is a warranty of high fire resistance for investment construction. At the same time, the product has high thermal and acoustic insulation. Its main applications are commercial, industrial, and public buildings.

ROCKWOOL's high-class insulation material is dual-density mineral wool slabs. The system is completed by sealing and fastening products from SFS INTEC that make installation faster and easier.

A curtain wall in the PROSYSTHERM system is class EI90 (it does not spread fire either inside or outside the building and remains fire-proof for up to 90 minutes). PROSYSTHERM is a set of several components that are very easy to assemble. We offer the system components in numerous variants (dimensions, material, colours). Such a system structure makes it possible to adjust the appearance and parameters of the covering to individual needs much more freely than in the case of composite panels.

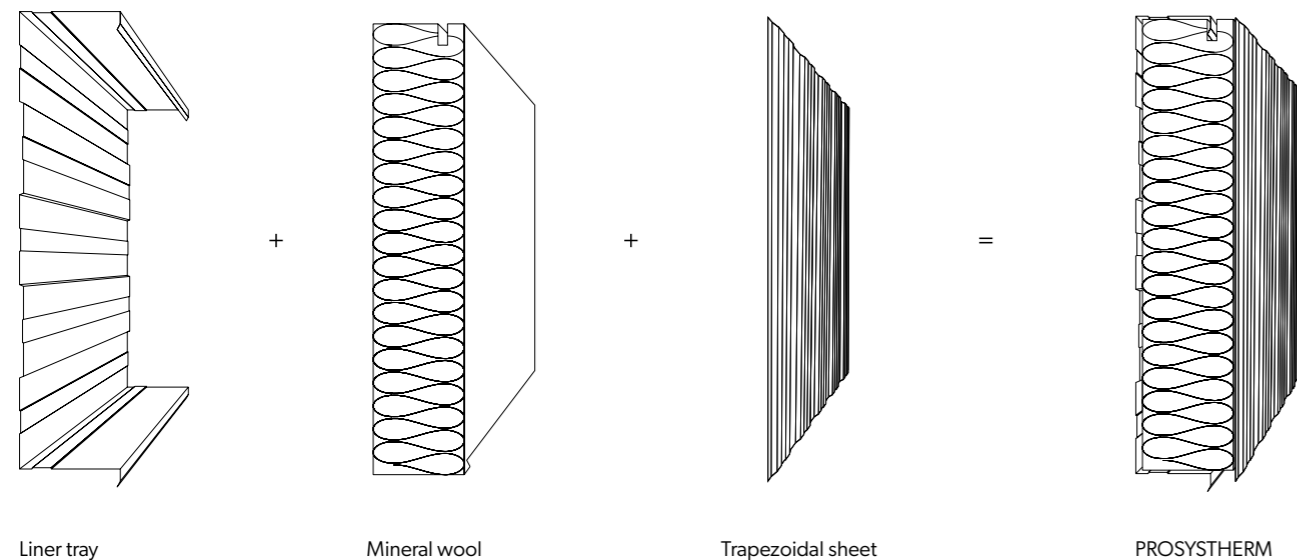

Sectional side view

Joining trays longitudinally

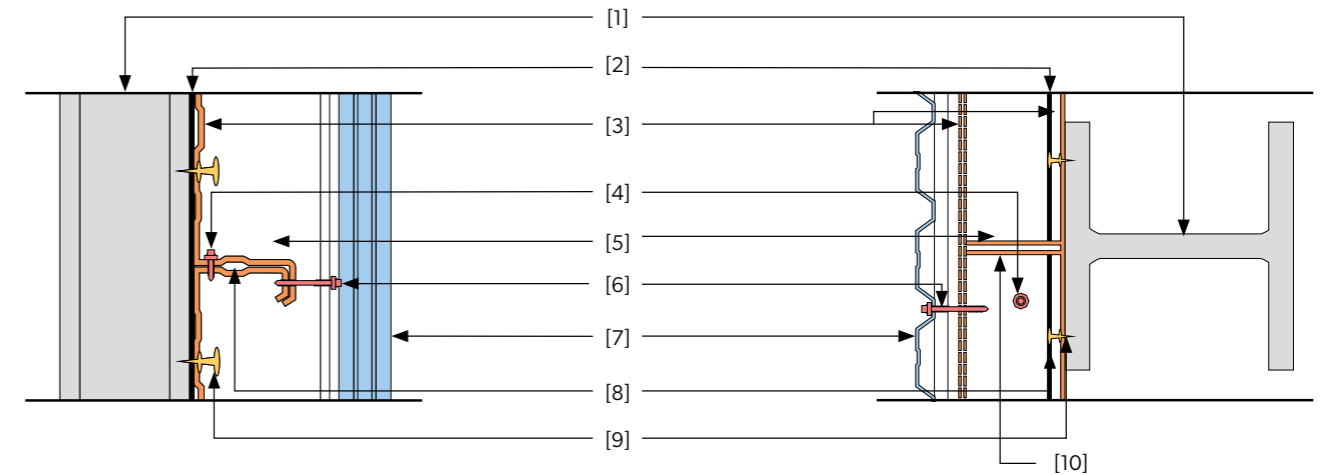

- [1] Support columns.
- [2] Gasket.
- [3] Liner tray (4 width variations).
- [4] 4.8×20 mm fastener.
- [5] Dual density mineral wool.
- [6] 5.5×63 mm spacer fastener.
- [7] Trapezoidal sheet.
- [8] Gasket.
- [9] Powder-actuated fastener (min. 3 per tray side).
- [10] Joining trays longitudinally.

### Traditional system - insulation with standard mineral wool:

The following diagram illustrates the most common problems with traditional mineral wool insulation methods. The innovative components of the PROSYSTHERM system, thanks to their unique properties, prevent all the problems indicated in the diagram.

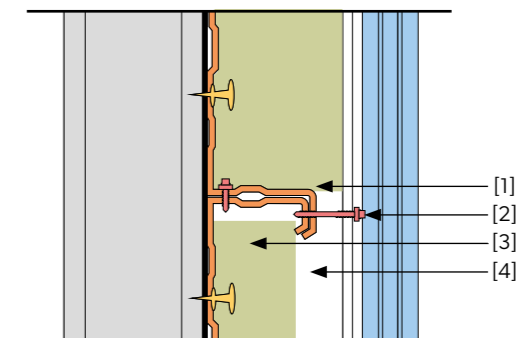

- [1] The occurrence of a thermal bridge effect causing freezing.
- [2] Transmission of vibrations (low sound insulation).
- [3] Wool settlement.
- [4] Incomplete utilisation of space for insulation.



# 12.

## Sandwich panels

128. Sandwich panels CORE PIR

138. Sandwich panels CORE WOOL



# SPW-S CORE<sup>PIR</sup>

## Wall panel with visible fastening

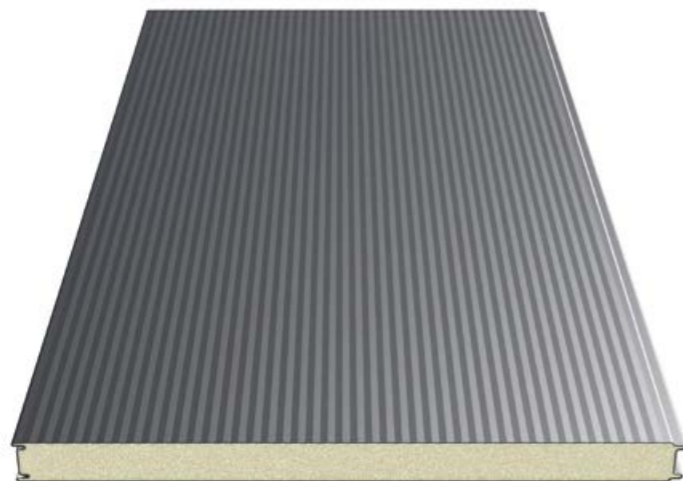

## Panel cross-section

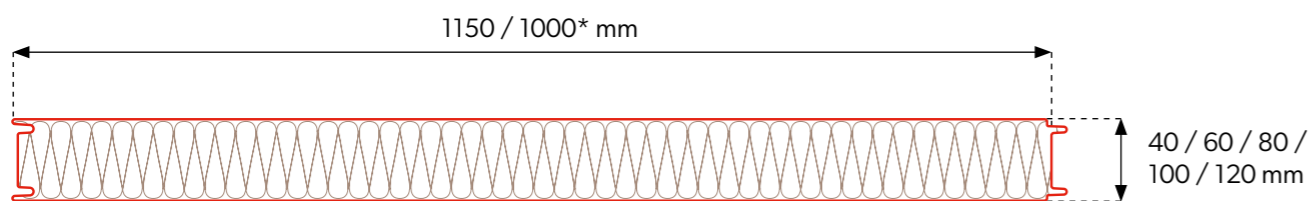

## Joining the panels

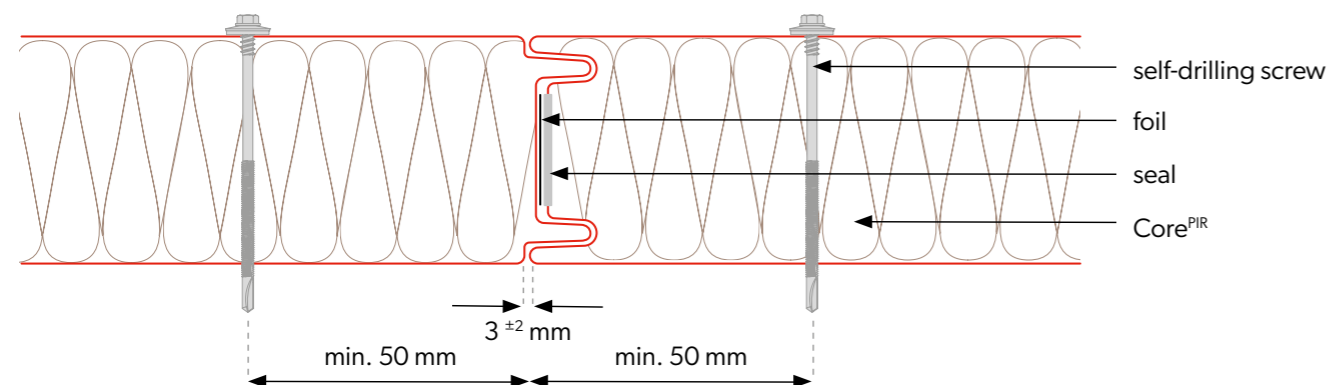

## Technical specifications

Core	<b>PIR</b>				
Density [kg/m <sup>3</sup> ]	<b>40 ± 3</b>				
PIR panel thickness [mm]	<b>40</b>	<b>60</b>	<b>80</b>	<b>100</b>	<b>120</b>
Weight [kg/m <sup>2</sup> ]	<b>8,7</b>	<b>9,5</b>	<b>10,3</b>	<b>11,1</b>	<b>11,9</b>
Effective width [mm]	<b>1150, 1000*</b>				
Total width [mm]	<b>1171, 1021*</b>				
Min. panel length [m]	<b>2,5</b>	<b>2,0</b>			
Max. panel length [m]	<b>15,0</b>				
Outer/inner sheet thickness [mm]	<b>0,4-0,7 / 0,4-0,7</b>				
U-value [W/m <sup>2</sup> K]	<b>0,55</b>	<b>0,37</b>	<b>0,28</b>	<b>0,22</b>	<b>0,18</b>
Fire spread degree	<b>NRO</b>				
Fire resistance				<b>EI15</b>	<b>EI30</b>
Type of external / internal profiling	<b>[M], [T], [R], [F] / [M], [T], [F]</b>				
External / internal corrosion resistance	<b>C1, C2, C3 (C4 ÷ C5) / A1 (A2 ÷ A5)</b>				
Standard coatings	<b>Poliester Interior [INT], Poliester Standard [RAL], HERCULIT [HC], MULTILAYER 40 [MLT]</b>				
Special coatings	<b>PVDF, PUR, PVC (P), PVC (F) - FoodSafe</b>				
Accessories	<b>fixing system, seals, flashings, rooflight SPR-SKY</b>				



\* Module availability is agreed individually with the sales department.

# SPW-H CORE<sup>PIR</sup>

## Sandwich wall panel with concealed fixing

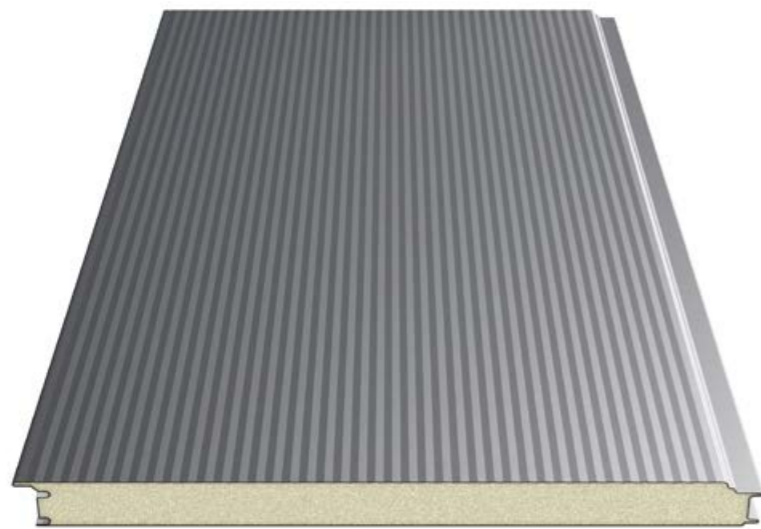

### Panel cross-section

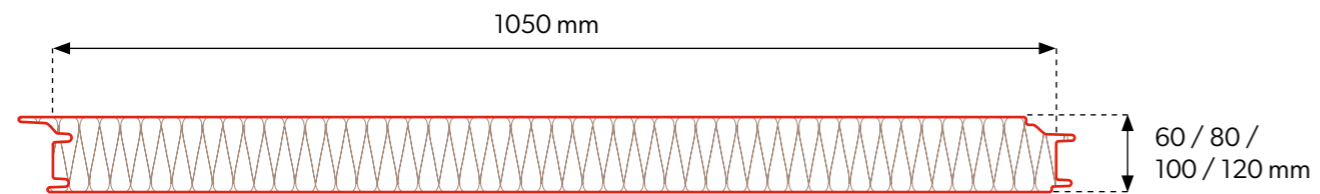

### Joining the panels

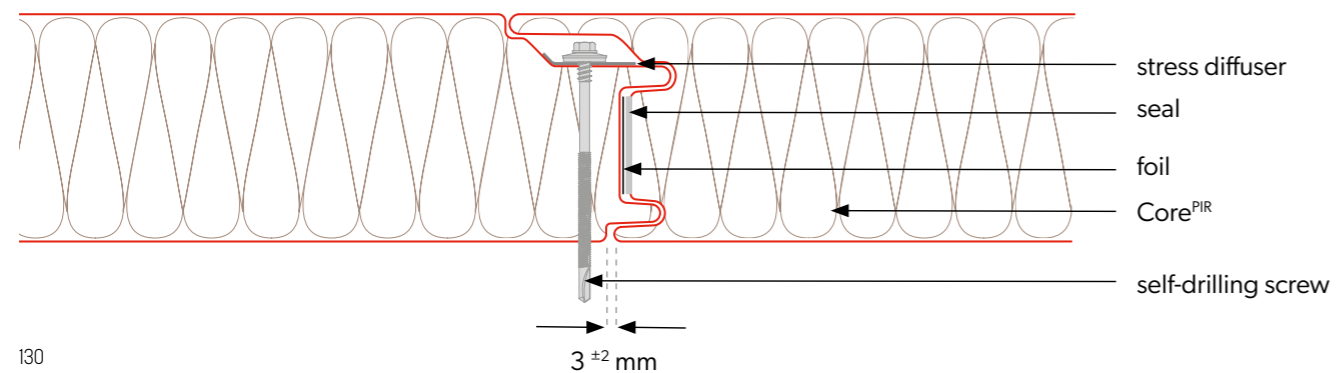

## Technical specifications

Core	PIR			
Density [kg/m <sup>3</sup> ]	40 ± 3			
PIR panel thickness [mm]	60	80	100	120
Weight [kg/m <sup>2</sup> ]	9,5	10,3	11,1	11,9
Effective width [mm]	1050			
Total width [mm]	1102			
Min. panel length [m]	2,0			
Max. panel length [m]	15,0			
Outer/inner sheet thickness [mm]	0,4-0,7 / 0,4-0,7			
U-value [W/m <sup>2</sup> K]	0,37	0,28	0,22	0,18
Fire spread degree	NRO			
Type of external / internal profiling	[M], [T], [R], [F] / [M], [T], [F]			
External / internal corrosion resistance	C1, C2, C3 (C4 ÷ C5) / A1 (A2 ÷ A5)			
Standard coatings	Poliester Interior [INT], Poliester Standard [RAL], HERCULIT [HC], MULTILAYER 40 [MLT]			
Special coatings	PVDF, PUR, PVC (P), PVC (F) - FoodSafe			
Accessories	fixing system, seals, flashings, rooflight SPR-SKY			

# SPW-C CORE<sup>PIR</sup>

## Cooling sandwich panel



### Panel cross-section

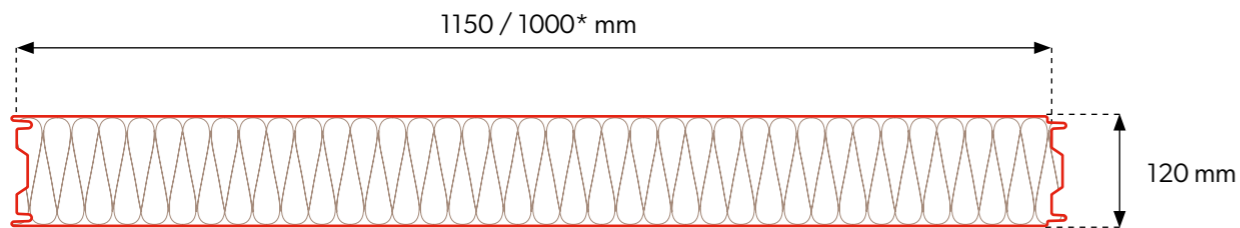

### Joining the panels

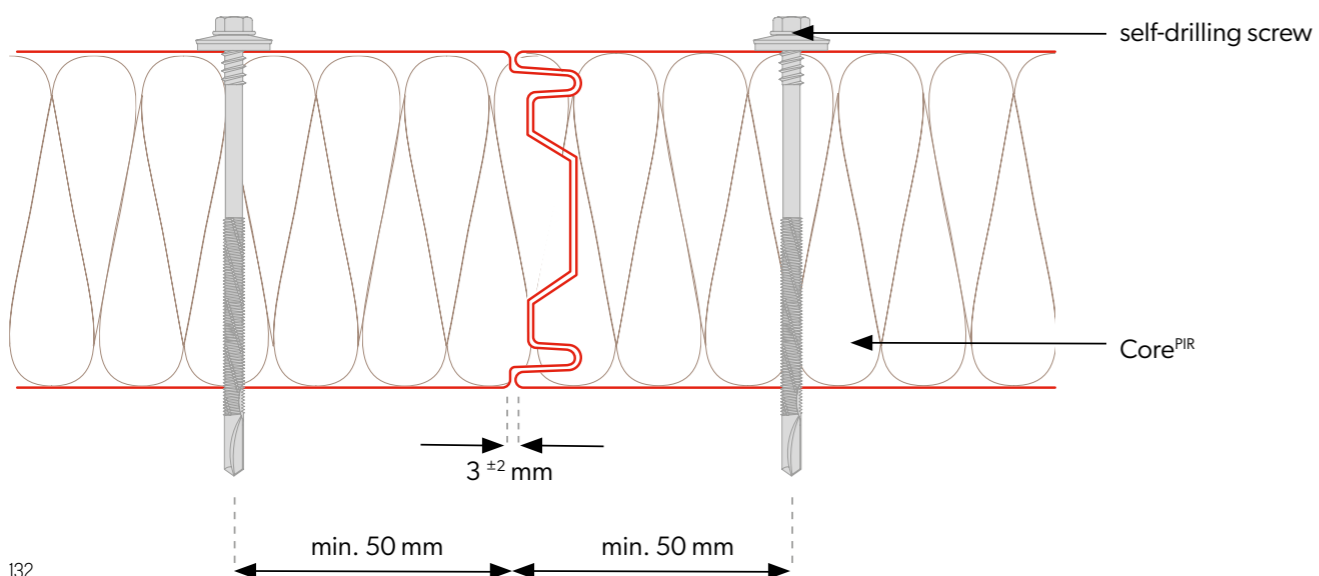

## Technical specifications

Core	PIR
Density [kg/m <sup>3</sup> ]	40 ± 3
PIR panel thickness [mm]	120
Weight [kg/m <sup>2</sup> ]	11,9
Effective width [mm]	1150, 1000*
Total width [mm]	1171, 1021*
Min. panel length [m]	2,0
Max. panel length [m]	15,0
Outer/inner sheet thickness [mm]	0,4-0,7 / 0,4-0,7
U-value [W/m <sup>2</sup> K]	0,18
Fire spread degree	NRO
Type of external / internal profiling	[M], [T], [R], [F] / [M], [T], [F]
External / internal corrosion resistance	C1, C2, C3 (C4 ÷ C5) / A1 (A2 ÷ A5)
Standard coatings	Poliester Interior [INT], Poliester Standard [RAL], HERCULIT [HC], MULTILAYER 40 [MLT]
Special coatings	PVDF, PUR, PVC (P), PVC (F) - FoodSafe
Accessories	fixing system, seals, flashings, rooflight SPR-SKY



\* Module availability is agreed individually with the sales department.

# SPW-C CORE<sup>PIR</sup>

## Cooling sandwich panel

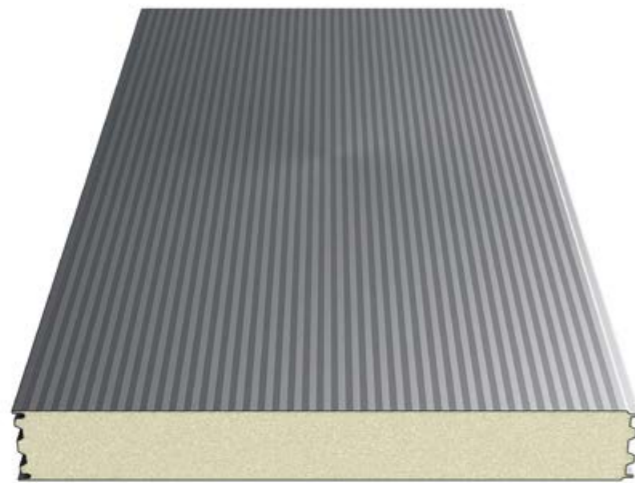

### Panel cross-section

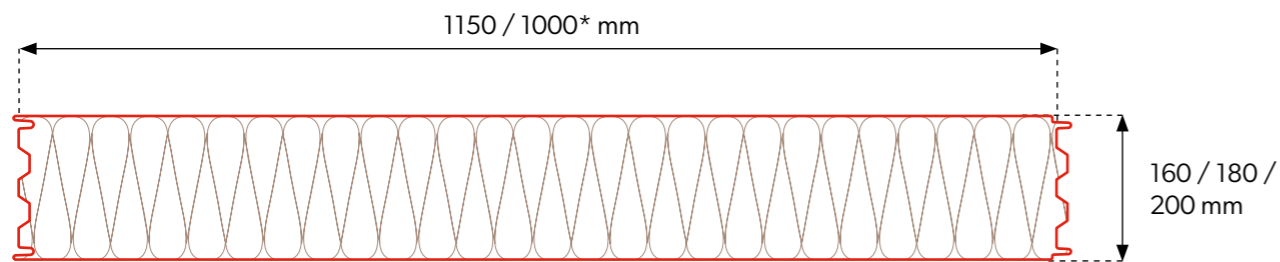

### Joining the panels

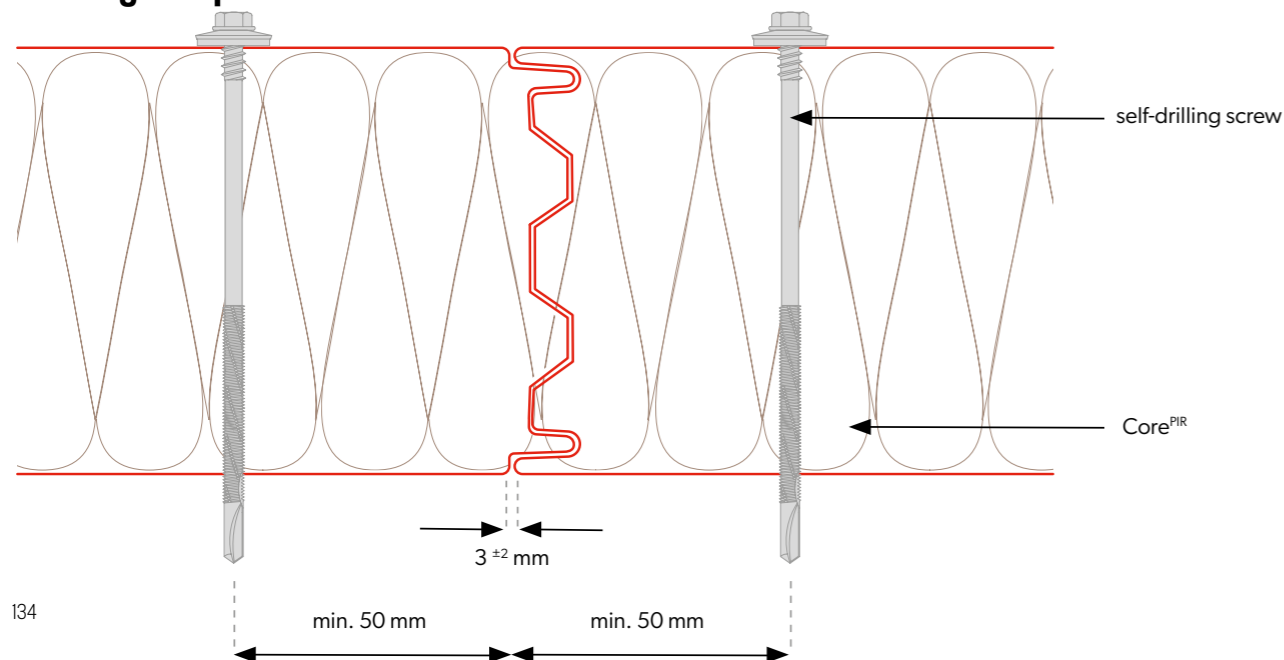

## Technical specifications

Core	PIR		
Density [kg/m <sup>3</sup> ]	40 ± 3		
PIR panel thickness [mm]	160	180	200
Weight [kg/m <sup>2</sup> ]	13,5	14,3	15,1
Effective width [mm]	1150, 1000*		
Total width [mm]	1171, 1021*		
Min. panel length [m]	2,0		
Max. panel length [m]	15,0		
Outer/inner sheet thickness [mm]	0,4-0,7 / 0,4-0,7		
U-value [W/m <sup>2</sup> K]	0,14	0,12	0,11
Fire spread degree	NRO		
Type of external / internal profiling	[M], [T], [R], [F] / [M], [T], [F]		
External / internal corrosion resistance	C1, C2, C3 (C4 ÷ C5) / A1 (A2 ÷ A5)		
Standard coatings	Poliester Interior [INT], Poliester Standard [RAL], HERCULIT [HC], MULTILAYER 40 [MLT]		
Special coatings	PVDF, PUR, PVC (P), PVC (F) - FoodSafe		
Accessories	fixing system, seals, flashings, rooflight SPR-SKY		



\* Module availability is agreed individually with the sales department.

# SPR CORE<sup>PIR</sup>

## Roof sandwich panel

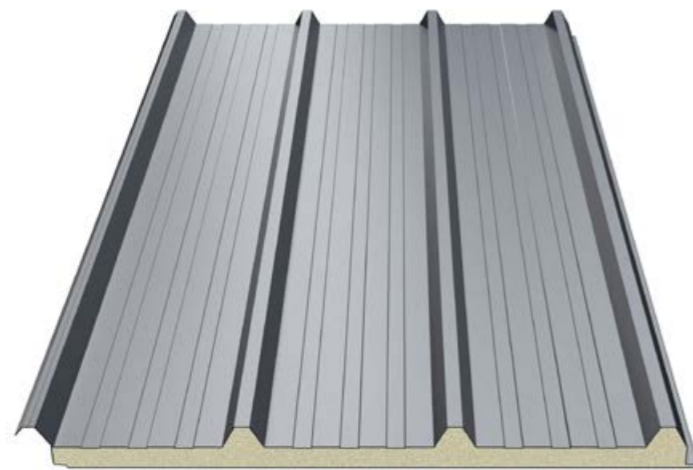

### Panel cross-section

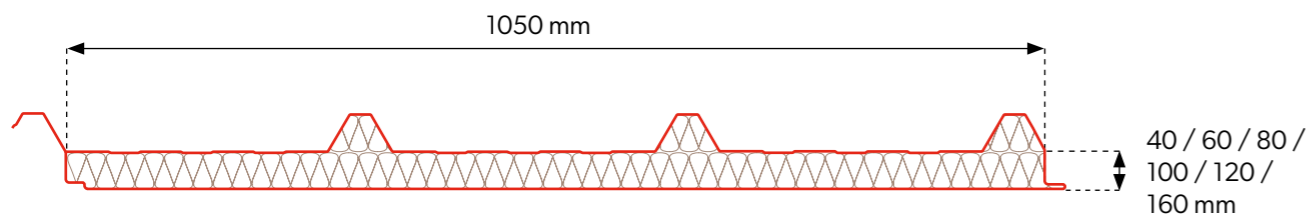

### Joining the panels

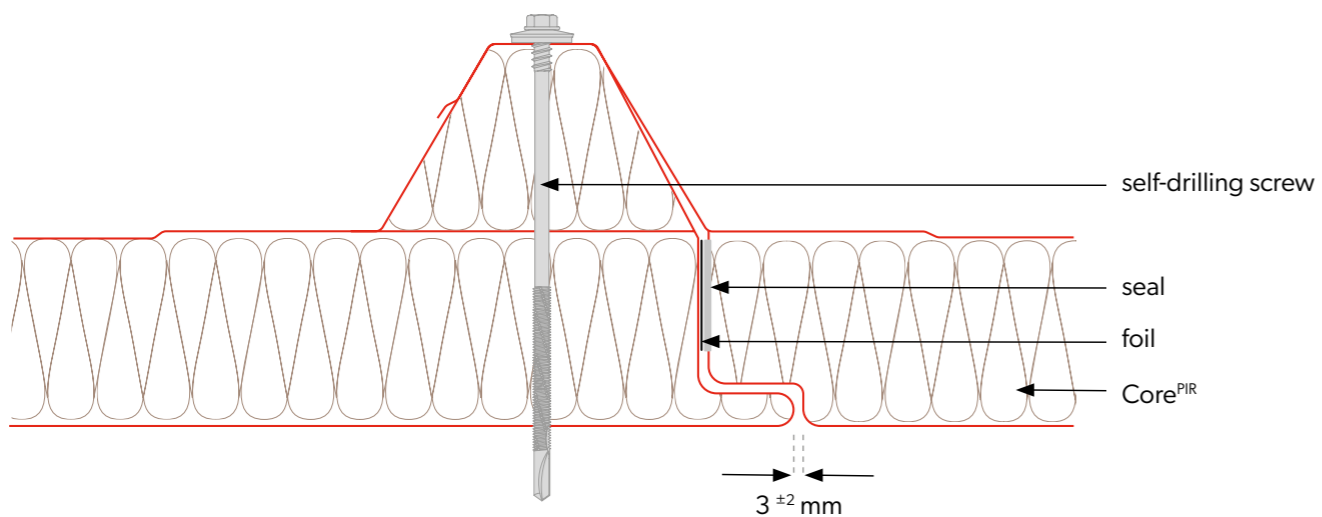

## Technical specifications

Core	<b>PIR</b>					
Density [kg/m <sup>3</sup> ]	<b>40 ± 3</b>					
PIR panel thickness [mm]	<b>40</b>	<b>60</b>	<b>80</b>	<b>100</b>	<b>120</b>	<b>160</b>
Weight [kg/m <sup>2</sup> ]	<b>9,6</b>	<b>10,4</b>	<b>11,2</b>	<b>12,0</b>	<b>12,8</b>	<b>14,8</b>
Effective width [mm]	<b>1050</b>					
Total width [mm]	<b>1127</b>					
Min. panel length [m]	<b>2,0</b>					
Max. panel length [m]	<b>15,0</b>					
Outer/inner sheet thickness [mm]	<b>0,4-0,7 / 0,4-0,7</b>					
U-value [W/m <sup>2</sup> K]	<b>0,55</b>	<b>0,37</b>	<b>0,28</b>	<b>0,22</b>	<b>0,18</b>	<b>0,14</b>
Fire spread degree	<b>NRO</b>					
Type of external / internal profiling	<b>[T40] / [M], [T], [F]</b>					
External / internal corrosion resistance	<b>C1, C2, C3 (C4 ÷ C5) / A1 (A2 ÷ A5)</b>					
Standard coatings	<b>Poliester Interior [INT], Poliester Standard [RAL], HERCULIT [HC], MULTILAYER 40 [MLT]</b>					
Special coatings	<b>PVDF, PUR, PVC (P), PVC (F) - FoodSafe</b>					
Accessories	<b>fixing system, seals, flashings, rooflight SPR-SKY</b>					

# SPW-S CORE WOOL

## Wall panel with visible fastening

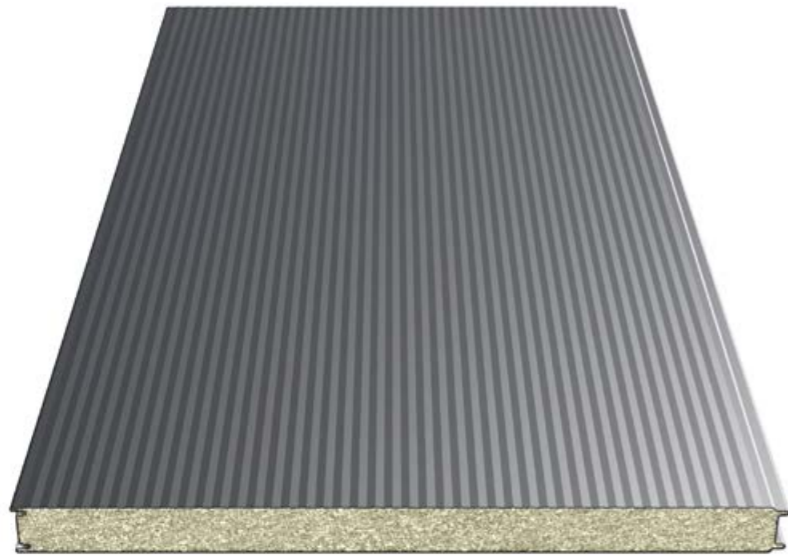

### Panel cross-section

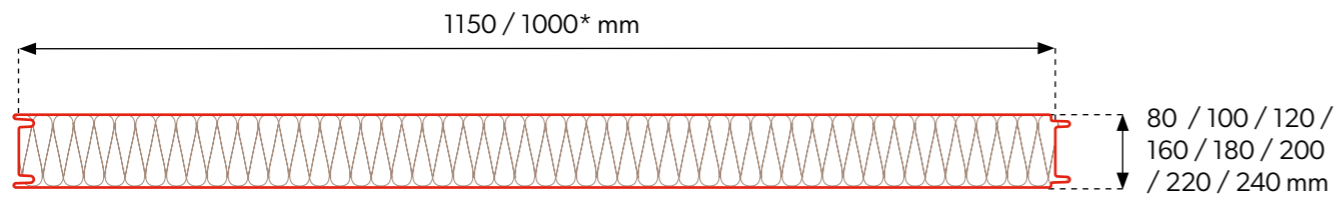

### Joining the panels

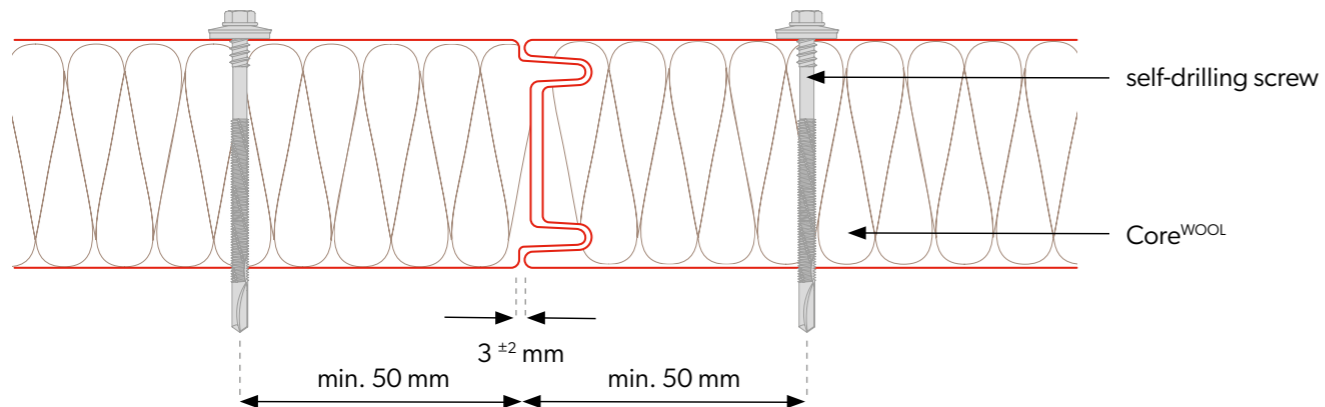

## Technical specifications

Core	<b>wool</b>							
Density [kg/m <sup>3</sup> ]	<b>100 ± 10</b>							
WOOL panel thickness [mm]	<b>80</b>	<b>100</b>	<b>120</b>	<b>160</b>	<b>180</b>	<b>200</b>	<b>220</b>	<b>240</b>
Weight [kg/m <sup>2</sup> ]	<b>16,6</b>	<b>18,6</b>	<b>20,6</b>	<b>24,6</b>	<b>26,6</b>	<b>28,6</b>	<b>30,6</b>	<b>32,6</b>
Effective width [mm]	<b>1150, 1000*</b>							
Total width [mm]	<b>1171, 1021*</b>							
Min. panel length [m]	<b>2,0</b>							
Max. panel length [m]	<b>15,0</b>							
Outer/inner sheet thickness [mm]	<b>0,5-0,7 / 0,5-0,7</b>							
U-value [W/m <sup>2</sup> K]	<b>0,54</b>	<b>0,43</b>	<b>0,36</b>	<b>0,27</b>	<b>0,24</b>	<b>0,22</b>	<b>0,20</b>	<b>0,18</b>
Fire spread degree	<b>NRO</b>							
Type of external / internal profiling	<b>[M], [T], [R], [F] / [M], [T], [F]</b>							
External / internal corrosion resistance	<b>C1, C2, C3 (C4 ÷ C5) / A1 (A2 ÷ A5)</b>							
Standard coatings	<b>Poliester Interior [INT], Poliester Standard [RAL], HERCULIT [HC], MULTILAYER 40 [MLT]</b>							
Special coatings	<b>PVDF, PUR, PVC (P), PVC (F) - FoodSafe</b>							
Accessories	<b>fixing system, seals, flashings, rooflight</b>							



\* Module availability is agreed individually with the sales department.

# SPW-SM CORE WOOL

## Wall panel with visible fastening

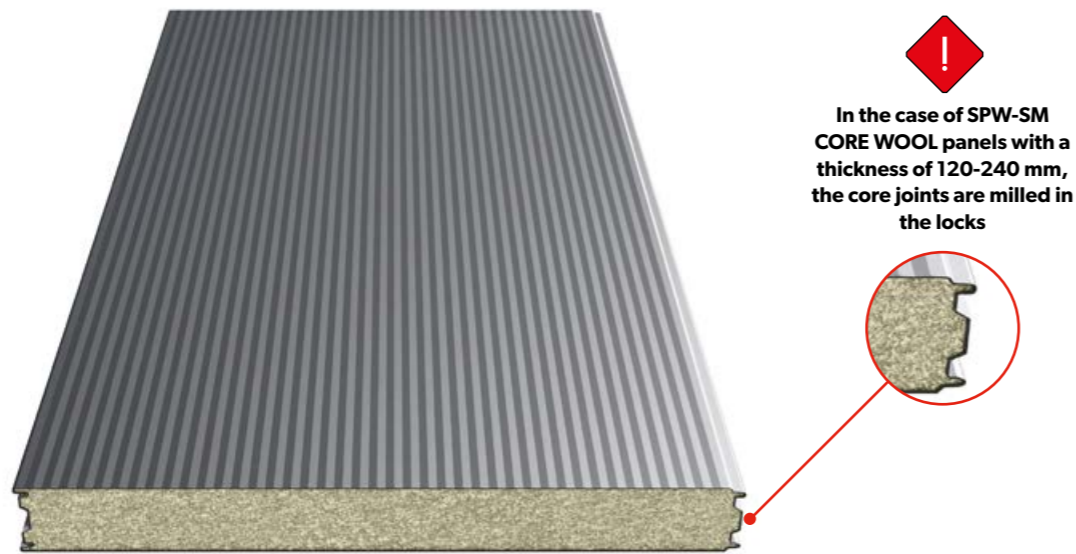

## Panel cross-section

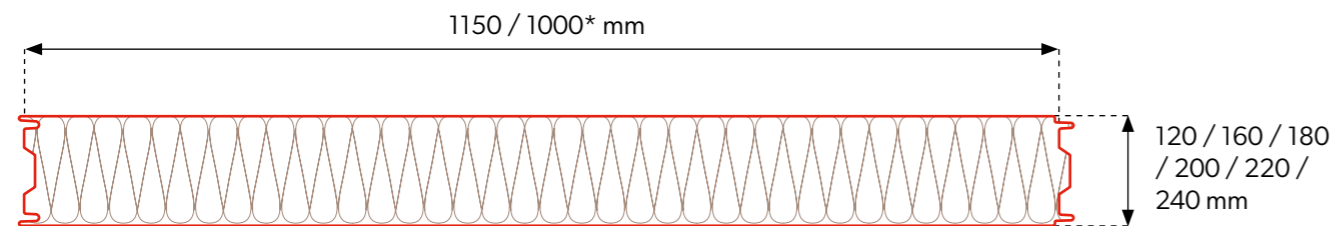

## Joining the panels

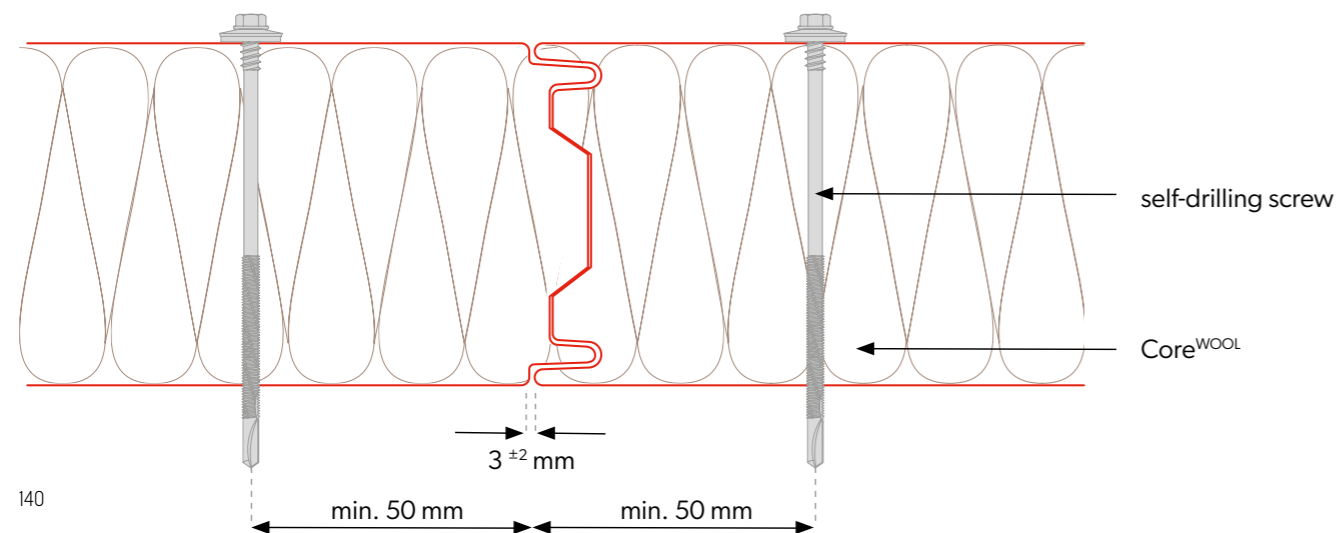

## Technical specifications

Core	weln					
Density [kg/m <sup>3</sup> ]	100 ± 10					
PIR panel thickness [mm]	120	160	180	200	220	240
Weight [kg/m <sup>2</sup> ]	20,6	24,6	26,6	28,6	30,6	32,6
Effective width [mm]	1150, 1000*					
Total width [mm]	1171, 1021*					
Min. panel length [m]	2,0					
Max. panel length [m]	15,0					
Outer/inner sheet thickness [mm]	0,5-0,7 / 0,5-0,7					
U-value [W/m <sup>2</sup> K]	0,36	0,27	0,24	0,22	0,20	0,18
Fire spread degree	NRO					
Type of external / internal profiling	[M], [T], [R], [F] / [M], [T], [F]					
External / internal corrosion resistance	C1, C2, C3 (C4 ÷ C5) / A1 (A2 ÷ A5)					
Standard coatings	Poliester Interior [INT], Poliester Standard [RAL], HERCULIT [HC], MULTILAYER 40 [MLT]					
Special coatings	PVDF, PUR, PVC (P), PVC (F) - FoodSafe					
Accessories	fixing system, seals, flashings, rooflight					



\* Module availability is agreed individually with the sales department.

# SPW-H CORE WOOL

## Sandwich wall panel with concealed fixing



### Panel cross-section

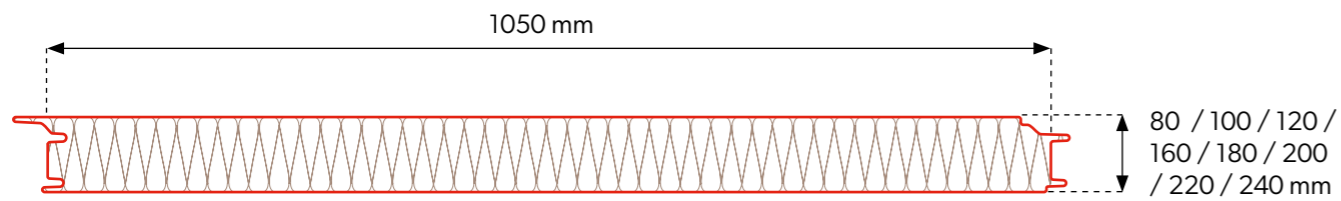

### Joining the panels

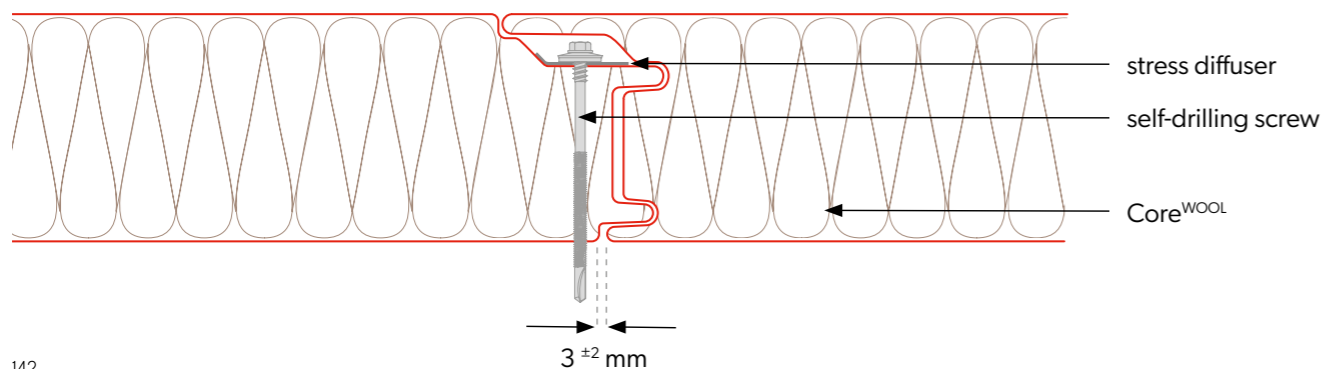

## Technical specifications

Core	wool							
Density [kg/m <sup>3</sup> ]	100 ± 10							
WOOL panel thickness [mm]	80	100	120	160	180	200	220	240
Weight [kg/m <sup>2</sup> ]	16,6	18,6	20,6	24,6	26,6	28,6	30,6	32,6
Effective width [mm]	1050							
Total width [mm]	1102							
Min. panel length [m]	2,5							
Max. panel length [m]	13,5							
Outer/inner sheet thickness [mm]	0,5-0,7 / 0,5-0,7							
U-value [W/m <sup>2</sup> K]	0,54	0,43	0,36	0,27	0,24	0,22	0,20	0,18
Fire spread degree	NRO							
Type of external / internal profiling	[M], [T], [R], [F] / [M], [T], [F]							
External / internal corrosion resistance	C1, C2, C3 (C4 ÷ C5) / A1 (A2 ÷ A5)							
Standard coatings	Poliester Interior [INT], Poliester Standard [RAL], HERCULIT [HC], MULTILAYER 40 [MLT]							
Special coatings	PVDF, PUR, PVC (P), PVC (F) - FoodSafe							
Accessories	fixing system, seals, flashings, rooflight							



# SPR CORE<sup>WOOL</sup>

## Roof sandwich panel



### Panel cross-section

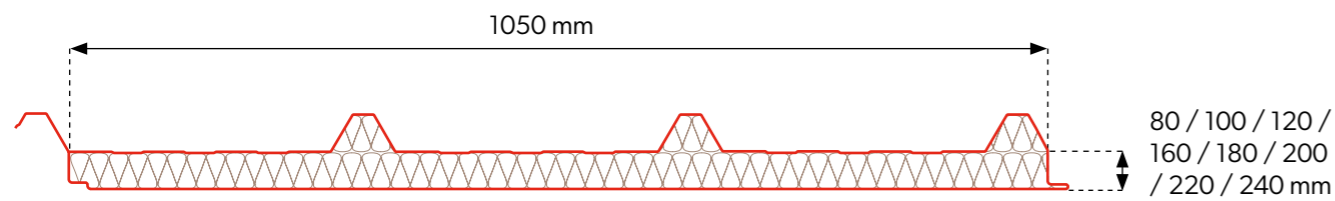

### Joining the panels

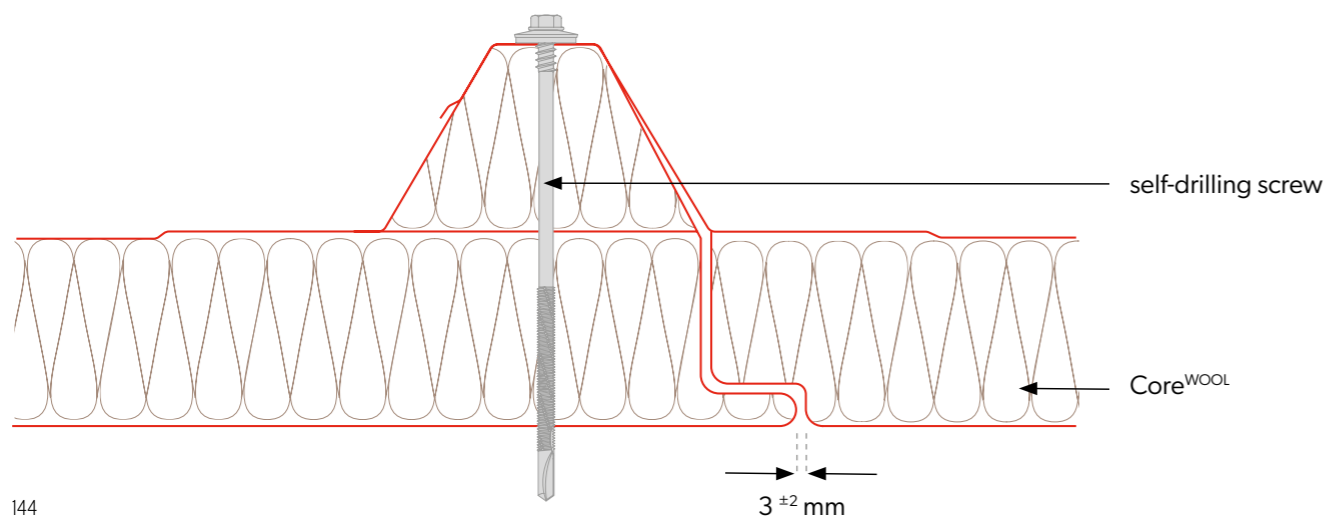

## Technical specifications

Core	<b>wool</b>							
Density [kg/m <sup>3</sup> ]	<b>100 ± 10</b>							
WOOL panel thickness [mm]	<b>80</b>	<b>100</b>	<b>120</b>	<b>160</b>	<b>180</b>	<b>200</b>	<b>220</b>	<b>240</b>
Weight [kg/m <sup>2</sup> ]	<b>17,8</b>	<b>19,8</b>	<b>21,8</b>	<b>25,8</b>	<b>27,8</b>	<b>29,8</b>	<b>31,8</b>	<b>33,8</b>
Effective width [mm]	<b>1050</b>							
Total width [mm]	<b>1127</b>							
Min. panel length [m]	<b>2,0</b>							
Max. panel length [m]	<b>15,0</b>							
Outer/inner sheet thickness [mm]	<b>0,5-0,7 / 0,5-0,7</b>							
U-value [W/m <sup>2</sup> K]	<b>0,54</b>	<b>0,43</b>	<b>0,36</b>	<b>0,27</b>	<b>0,24</b>	<b>0,22</b>	<b>0,20</b>	<b>0,18</b>
Fire spread degree	<b>NRO</b>							
Type of external / internal profiling	<b>[T40] / [M], [T], [F]</b>							
External / internal corrosion resistance	<b>C1, C2, C3 (C4 ÷ C5) / A1 (A2 ÷ A5)</b>							
Standard coatings	<b>Poliester Interior [INT], Poliester Standard [RAL], HERCULIT [HC], MULTILAYER 40 [MLT]</b>							
Special coatings	<b>PVDF, PUR, PVC (P), PVC (F) - FoodSafe</b>							
Accessories	<b>fixing system, seals, flashings, rooflight SPR-SKY</b>							

# Wall sandwich panels

## External profiling

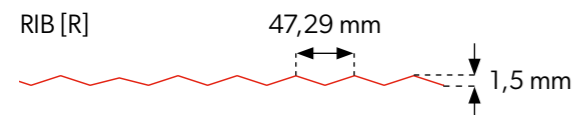
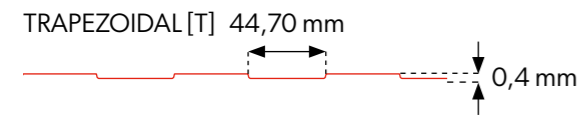
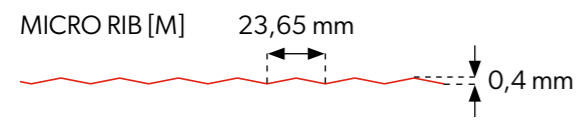

FLAT [F]

## Internal profiling

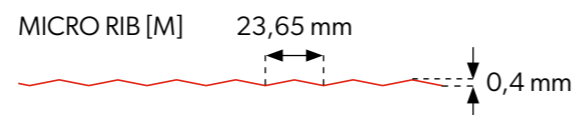
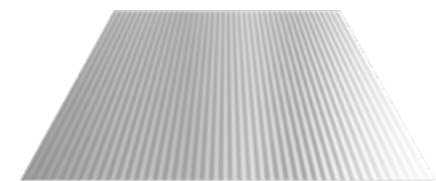
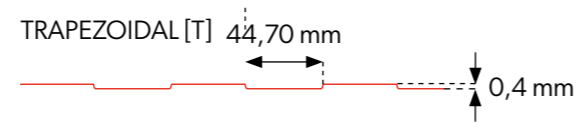
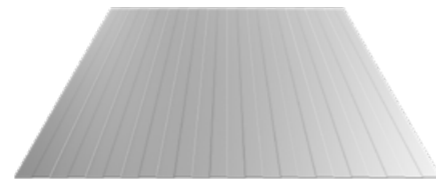

FLAT [F]



ATTENTION! Due to the structure of sandwich panels with FLAT [F] profiles, the so-called effect may occur. „waves“ of the sheet metal. This is a natural phenomenon for this type of products. We recommend contacting the technical department to choose the optimal solution.



Internal and external profiling are available in any configuration.

# Roof sandwich panels

## External profiling

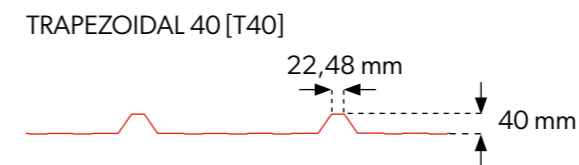
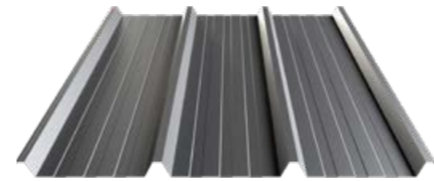

## Internal profiling

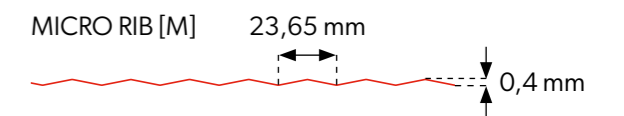
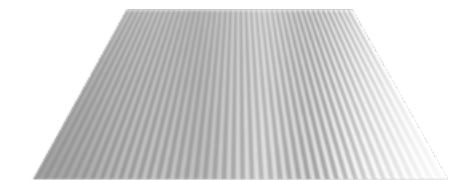
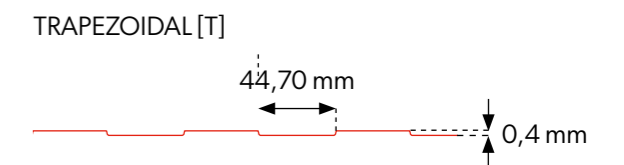
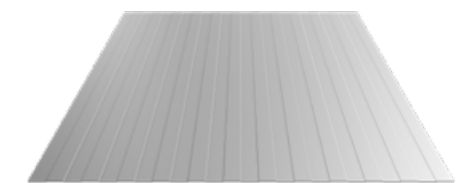

FLAT [F]



ATTENTION! Due to the structure of sandwich panels with FLAT [F] profiles, the so-called effect may occur. „waves“ of the sheet metal. This is a natural phenomenon for this type of products. We recommend contacting the technical department to choose the optimal solution.



Internal and external profiling are available in any configuration.



# 13.

## Cladding cassettes & panels

150. SKRIN cladding cassettes

151. Technical specifications

160. LINEA cladding panels

161. Colours and perforation



# SKRIN cladding cassettes



### Technical parameters

Width A1 min/max - horizontal installation	300/3000 mm
Height B1 min/max - horizontal installation	300/800 mm
Width A1 min/max - vertical installation	300/3000 mm
Height B1 min/max - vertical installation	300/1000 mm
Thickness C1	30 mm
Joint width - FH horizontal/FV vertical	25/25 mm
Mounting holes	oval 6x15 mm, round Ø 9 mm
Ventilation holes	oval 6x15 mm
Sheet thickness	1,25 mm
Coatings and colours	acc. to individual requirements
Fastener	visible/concealed
Installation method	horizontal/vertical

### SKRIN maximum and minimal dimensions

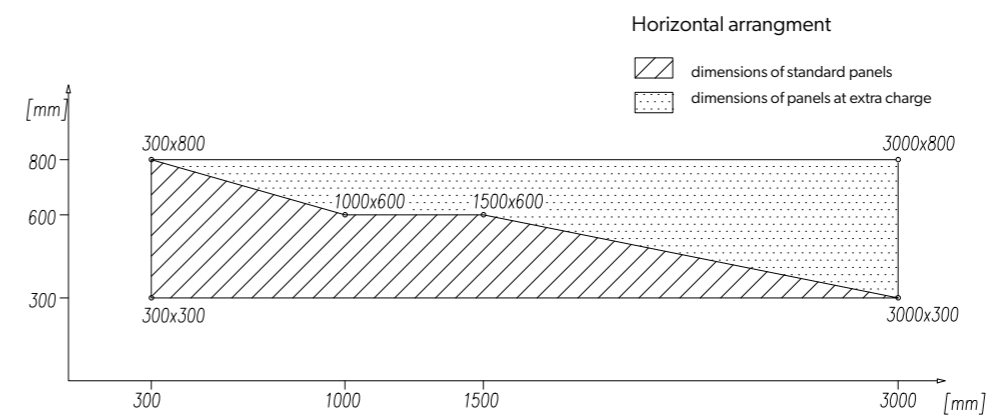
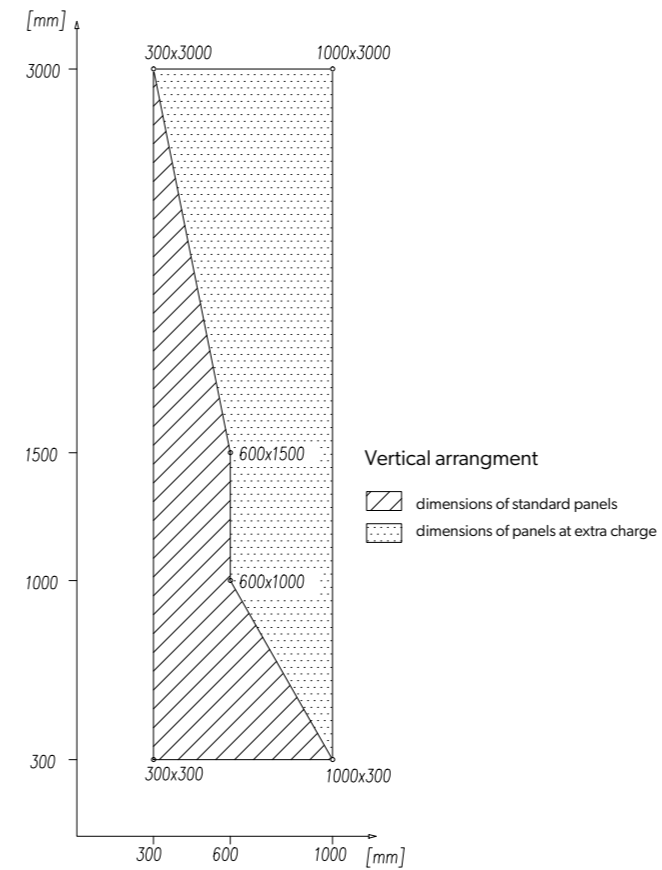

We offer perforation of SKRIN cladding cassettes. Details (shape, size, hole pattern, etc.) are agreed individually with the sales department. **For more information, see page 168..**

**Basic panel for horizontal installation**

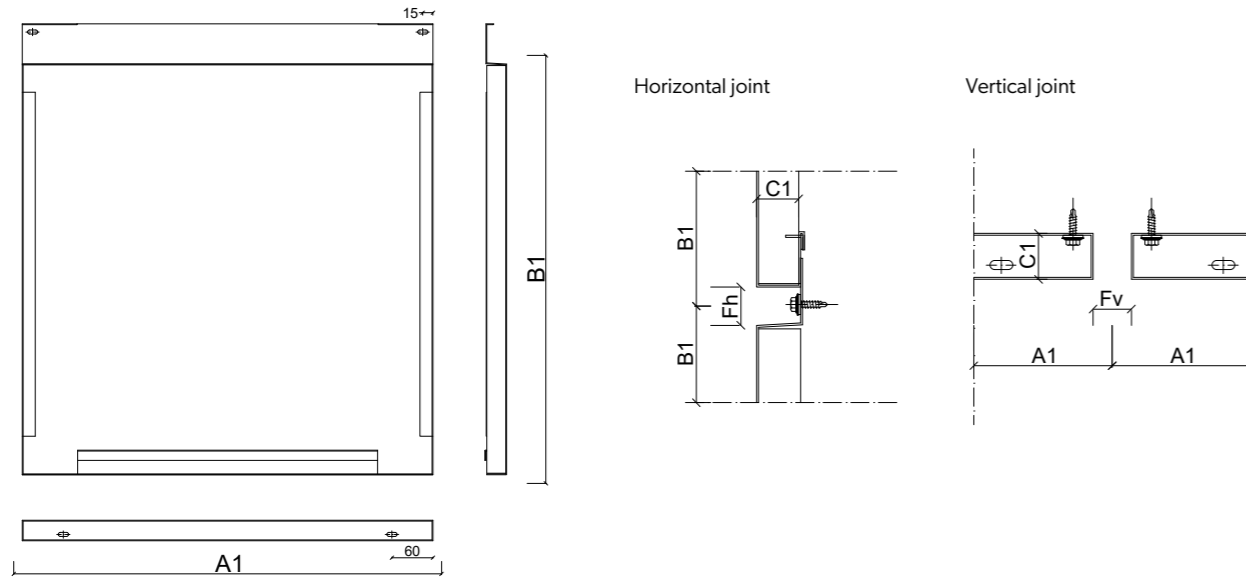

**L-shaped corner panel for horizontal installation.**

$A1_{max} + A2_{max} = 3000$  mm,  $A1_{min} = 300$  mm,  $A2_{min} = 300$  mm  
 $B1_{min} = 300$  mm,  $B1_{max} = 800$  mm

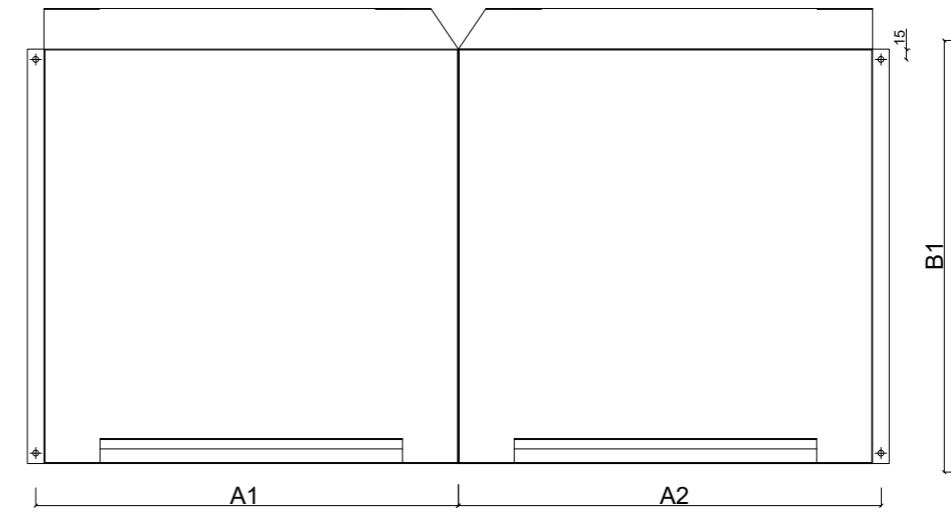

**Basic panel for vertical installation**

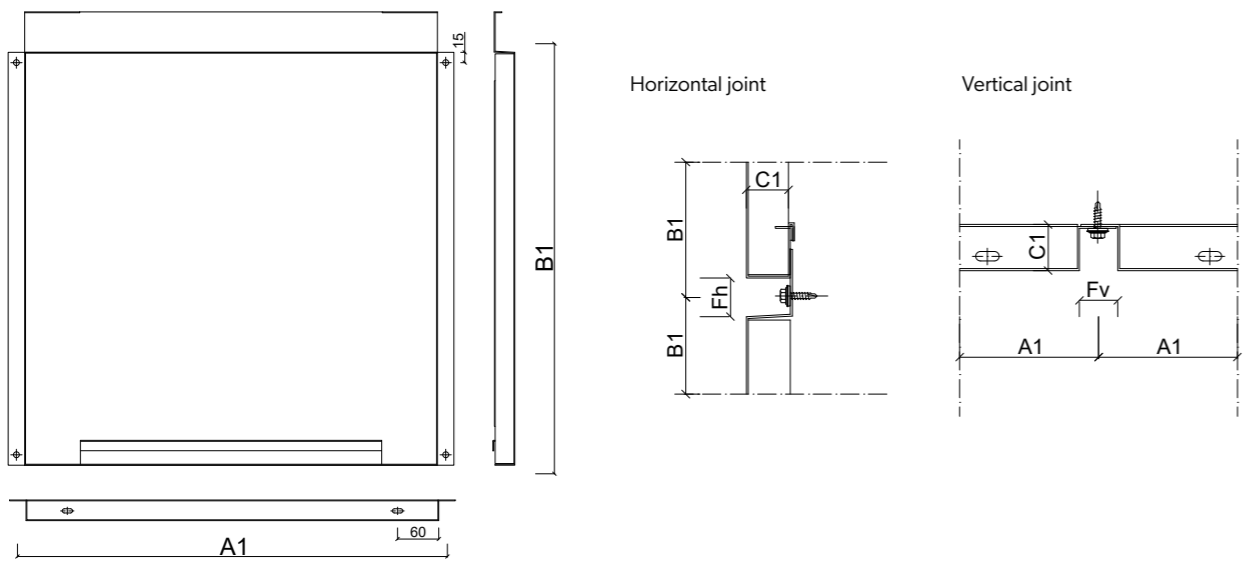

**U-shaped corner panel for horizontal installation.**

$A1_{max} + A2_{max} + A3_{max} = 3000$  mm,  $A1_{min} = 300$  mm,  $A2_{min} = 300$  mm  
 $B1_{min} = 300$  mm,  $B1_{max} = 800$  mm,  $B1_{min} = 300$  mm,  $B1_{max} = 800$  mm

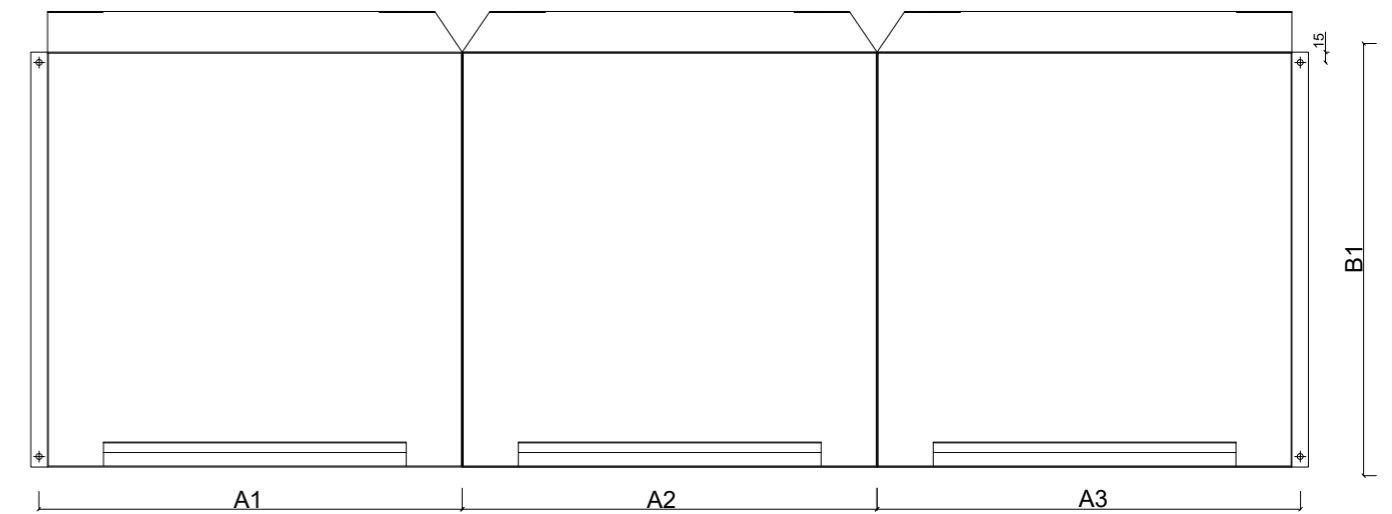

**L-shaped corner panel for vertical installation.**

$A1_{max} + A2_{max} = 1000$  mm,  $A1_{min} = 300$  mm,  $A2_{min} = 300$  mm  
 $B1_{min} = 300$  mm,  $B1_{max} = 3000$  mm

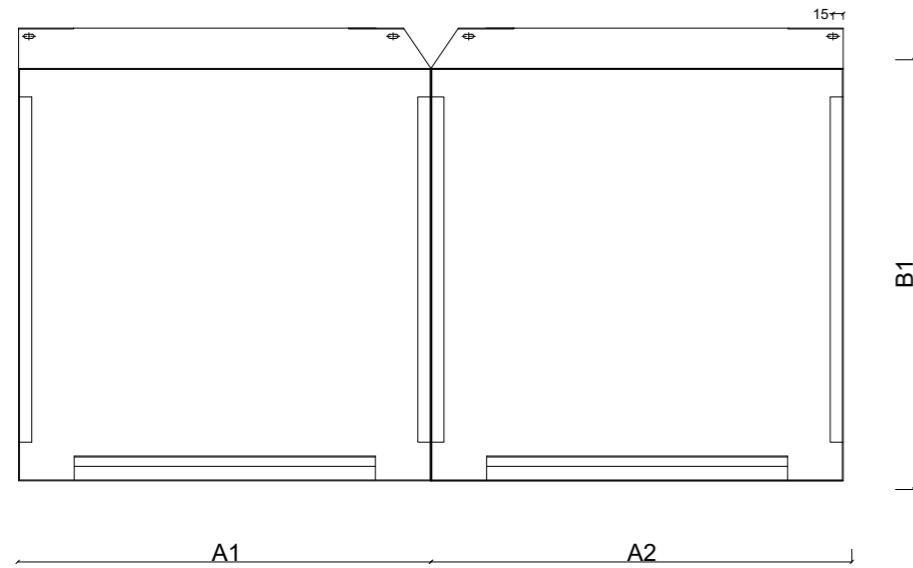

**Trapezoidal panel for horizontal installation.**

$A1_{max} = 3000$  mm,  $A1_{min} = 300$  mm,  
 $B1_{min}, B2_{min} = 300$  mm,  $B1_{max}, B2_{max} = 800$  mm

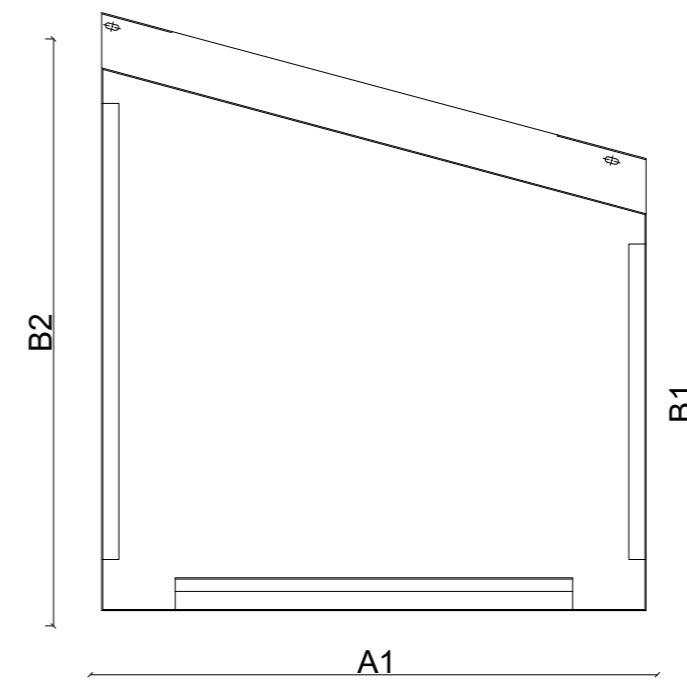

**U-shaped corner panel for vertical installation.**

$A1_{max} + A2_{max} + A3_{max} = 1000$  mm,  $A1_{min} = 300$  mm,  $A2_{min} = 300$  mm,  $A3_{min} = 300$  mm,  
 $B1_{min} = 300$  mm,  $B1_{max} = 3000$  mm

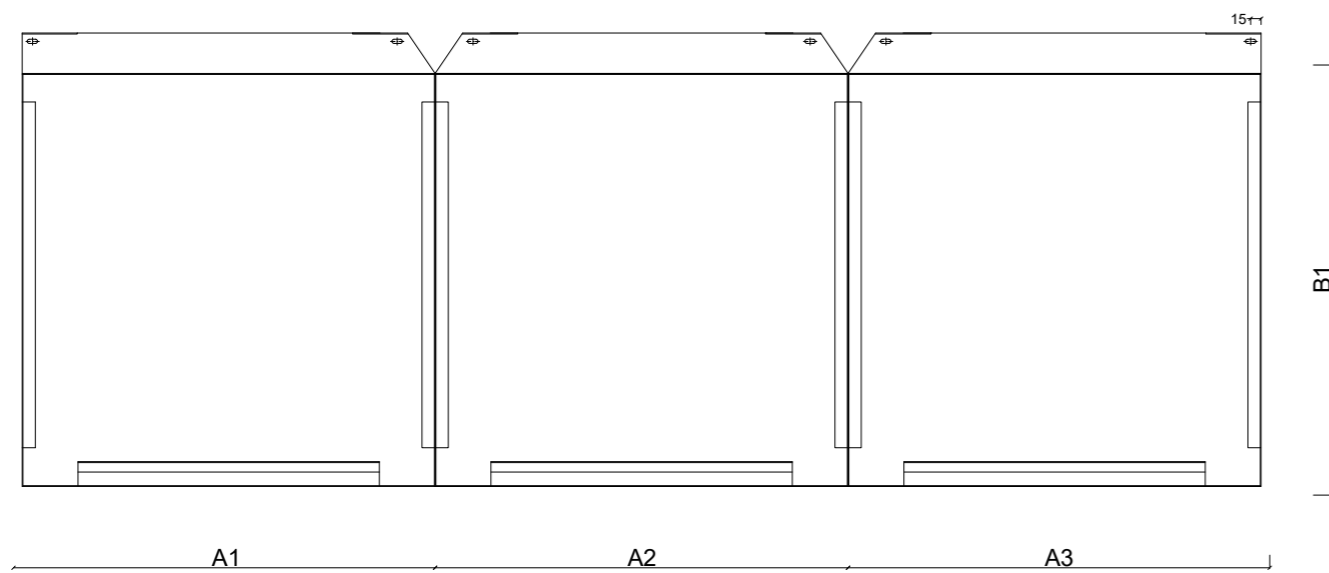

**Trapezoidal panel for vertical installation.**

$A1_{min} = 300$  mm,  $A1_{max} = 1000$  mm,  $B1_{min}, B2_{min} = 300$  mm,  
 $B1_{max}, B2_{max} = 3000$  mm

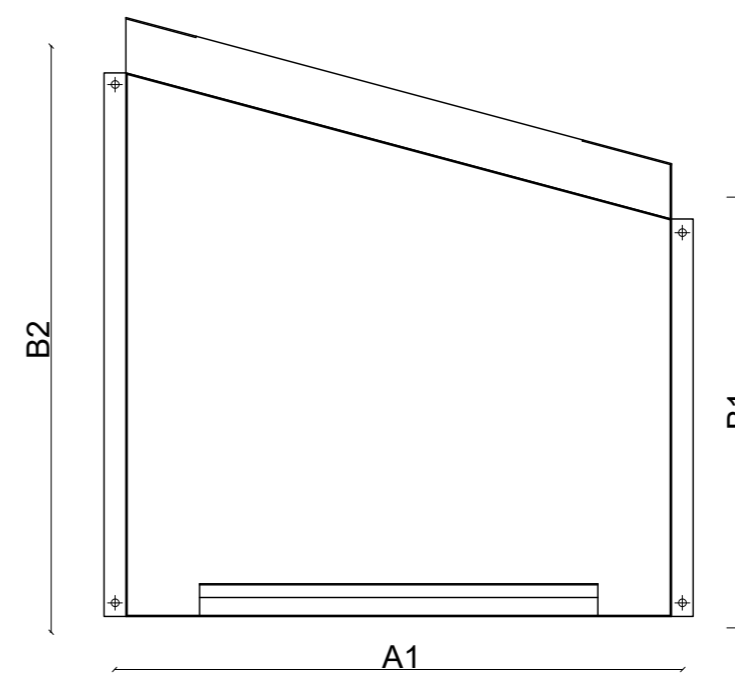

P03

Basic profile 20/90

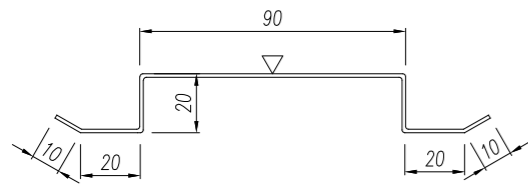

P02

Final profile 20/50

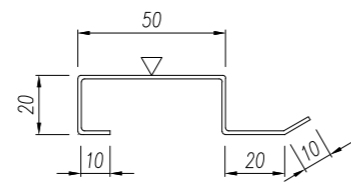

P01

Intermediate profile 20/50

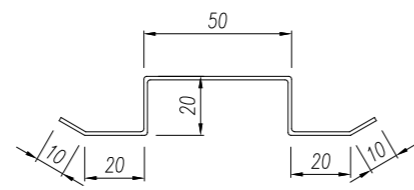

P04

Corner profile 20/160

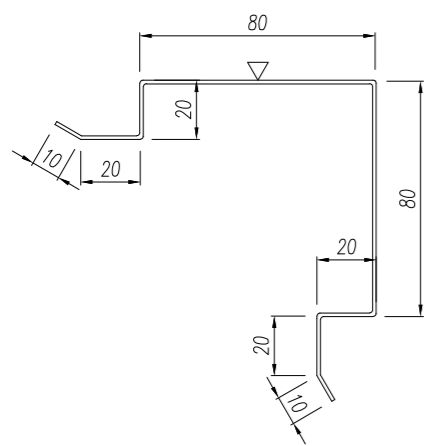

O01

Starting profile

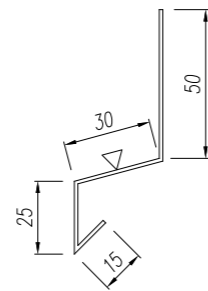

O04

Horizontal top window flashing

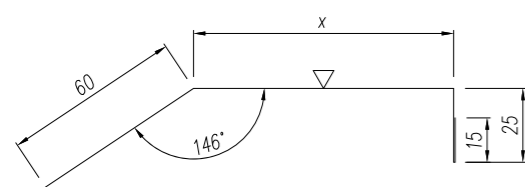

O08

Treatment of the connection to another façade element

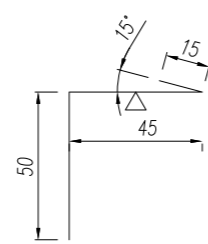

O05

Horizontal bottom window flashing

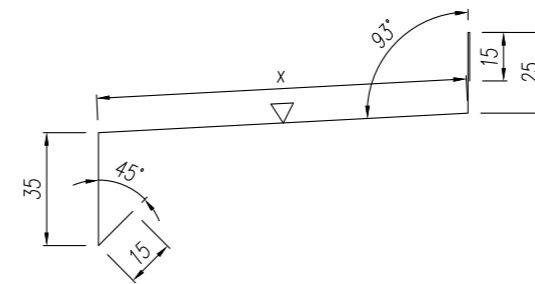

O06

Horizontal bottom window flashing bracket

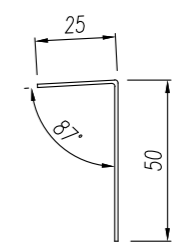

O07

Vertical window flashing

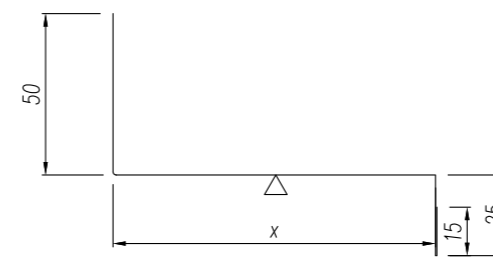

O03

Internal corner flashing

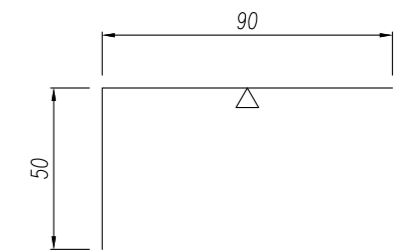

O02

Parapet cap

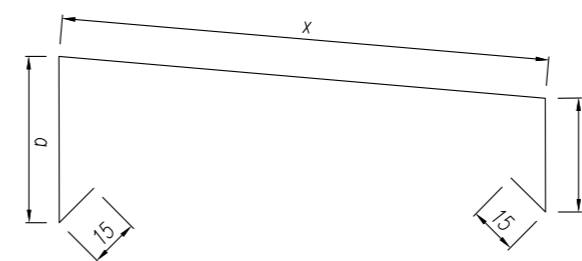

P07

Parapet cap bracket

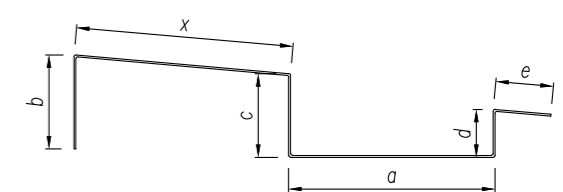

The use of SKRIN cladding cassettes allows for an aesthetic and durable finish of the façade. They can be used on the whole building or on selected representative parts, such as front elevations or office areas of buildings. Distinguishing the form and finishing materials of individual parts of the building's façade is a common solution in modern construction.

In such projects, cladding cassettes are an ideal choice due to their wide range of colours and flexible dimensions. In order to maintain the high aesthetics and functionality of the façade, we supply system corners and individually manufactured flashings.

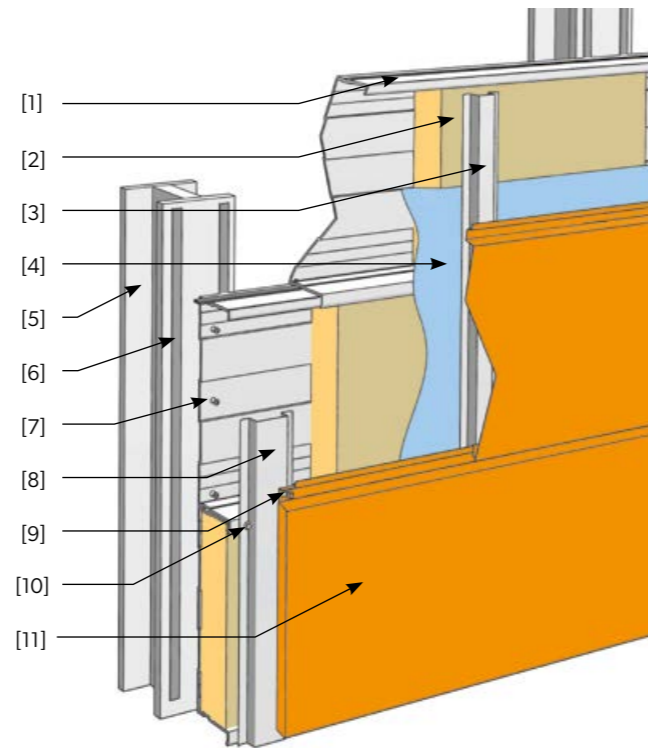

- [1] steel liner tray.
- [2] mineral wool - thermal insulation.
- [3] 20/50 P01 intermediate profile.
- [4] breather membrane.
- [5] support column.
- [6] sealing.
- [7] fastener (dowel or screw).
- [8] 20/90 P03 basic profile.
- [9] self-drilling fastener.
- [10] self-drilling fastener.
- [11] SKRIN cladding cassette.

An advantage of curtain walls built using SKRIN cladding cassettes is the fast and uncomplicated assembly. They can be used on any wall as they are hung on a substructure consisting of a steel grate made of P03 20/90 basic profiles.

SKRIN cassettes are mounted on them through bead holes to enable stress compensation. As the P03 20/90 basic profiles form the basis for joining the cassettes vertically, they are made of the same colour as the cassettes, giving a uniform surface effect. For additional stiffening, intermediate profiles P01 20/50 are used. The cassettes are joined horizontally by means of a locking joint principle with appropriately profiled upper and lower cassette edges.

- [1] masonry wall.
- [2] Z-profile steel girt.
- [3] vertical mounting grid from profiles.
- [4] mineral wool - thermal insulation.
- [5] breather membrane.
- [6] SKRIN cladding cassette.

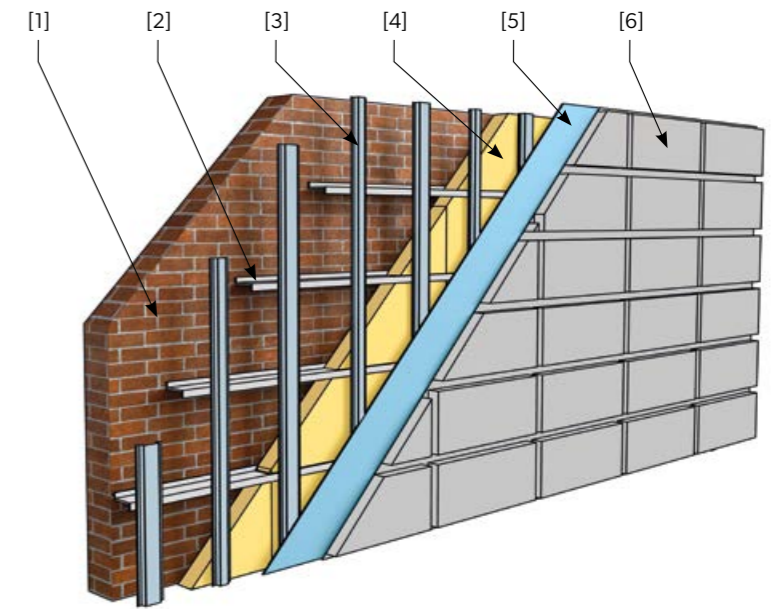





# LINEA cladding panels

LINEA cladding panels are ideal for combining with other types of cladding within the façade, such as cladding cassettes or LAMBDA 2.0 standing seam panels, which ensures an attractive visual effect.

Combined with a wide choice of colours and coating textures, this enables original façade designs to be executed. In order to compensate for stresses arising due to thermal expansion of the material, the deflection of the front surface (convexity) must be taken into account when installing the panels.



The main advantages of LINEA cladding panels are easy and quick installation and flexibility in adjusting the covering to the shape of the façade.

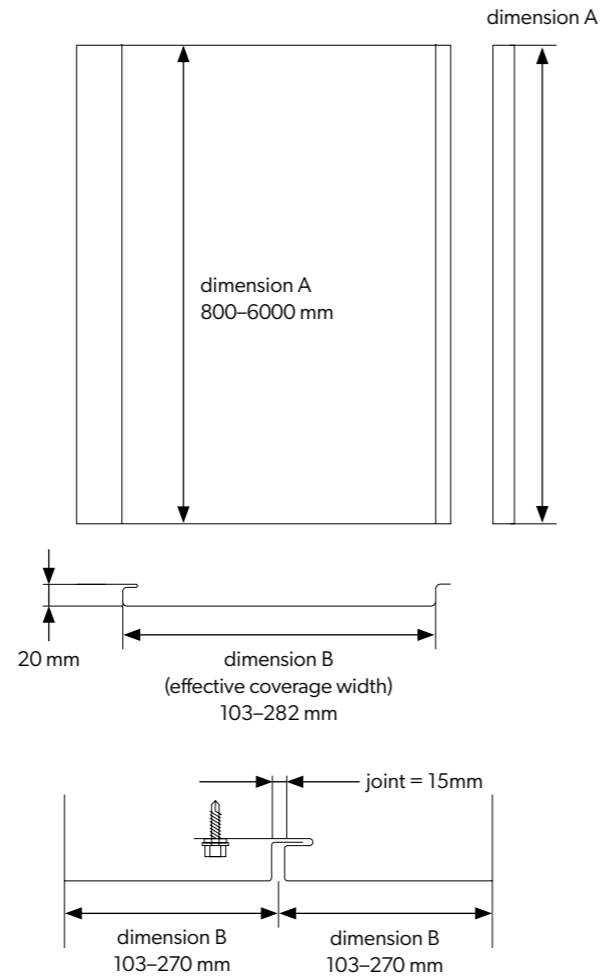

Ranges of standard cladding panel dimensions [mm]					Zakresy standardowych wymiarów paneli elewacyjnych [mm]				
Panels without joint					Panels with joint 15 mm				
Product code	Effective width	Panel face	Range of sheet thickness	Covering length	Product code	Effective width	Panel face	Range of sheet thickness	Covering length
PS 282.417	282	282	0,7-1,0	800-6000	PSF 270.417.15	270	255	0,7-1,0	800-6000
PS 177.312	177	177			PSF 165.312.15	165	150		
PS 115.250	115	115			PSF 103.250.15	103	88		

## Colours



We offer perforation of LINEA cladding panels. Details (shape, size, hole pattern, etc.) are agreed individually with the sales department.  
**For more information, see page 168..**



It is possible to manufacture non-standard LINEA panels. Details are agreed individually with the sales department.



Printing technology does not allow for faithful colour rendition, so the colours shown are approximate and may differ from actual colours.



In addition, custom colours and coatings are available upon individual request, outside of the palette shown.



# 14.

## Steel Service Centre

164. Steel service centre

165. Range of offerings

166. Cutting and recoiling services

167. Protection and packaging

168. Perforation of sheets

# Steel Service Centre

The Steel Service Centre (SSC) has been created for customers looking for a material with specific properties and processing levels. We ensure constant availability of a wide range of steel grades and coatings and the possibility of processing individual orders with any parameters. Processing includes recoiling, slitting and cross-cutting, as well as securing with protective film according to individual requirements.

We can also accept orders using material from customers, and the high quality of our production processes allows for its optimal use.



## Range of offerings

### SLITTING - LONGITUDINAL CUTTING

We supply low and highly processed steel material used in the production of a wide range of products. We have cutting and slitting lines for sheets and coils. We provide the possibility of covering the material with anti-condensation coating or protective film with individually determined parameters and properties.

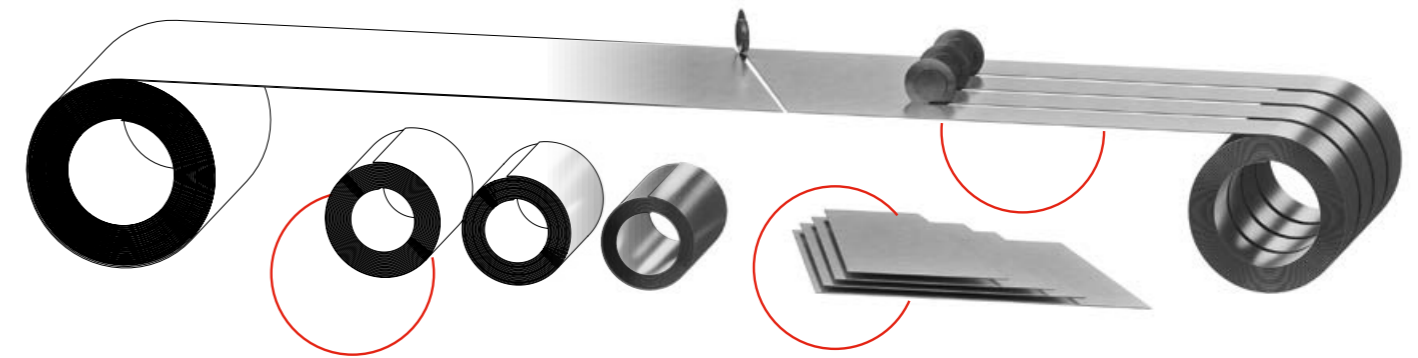

### COILS REWINDING

We provide rewinding services for coils weighing up to 25 t. We provide fast rewinding process and low output weights of coils. We can cover the strips with anti-condensation coating or protective film. The processed material is professionally protected and packaged.

### FORMATS - CROSS-CUTTING



We offer cross-cutting into sheets and formats, as well as oblique cutting into trapezoidal and rhomboid formats. Our offer includes a wide range of sizes and shapes, cutting with increased flatness (according to individually agreed EN standards) as well as protection and packaging of the material. **Slant cutting of formats: up to 35 degrees of inclination.**

## Protection and packaging

The processed material is professionally protected and stored. The lengthwise cut coils are stored vertically on a rack and strapped with steel bands or protected with stretch film.

In the case of formats, sorting and packaging is customised according to the order received.



TYPES OF MATERIAL				
		Coils [mm]	Ribbons [mm]	Formats [mm]
Hot-rolled sheets	Thickness	1,5 - 4	1,5 - 4	1,5 - 4
	Width	400 - 1650	30 - 1650	200 - 1650
	Length	N/A	N/A	220 - 6000
Cold-rolled sheets (coated, uncoated)	Thickness	0,4 - 3	0,4 - 3	0,4 - 3
	Width	400 - 1650	30 - 1650	200 - 1650
	Length	N/A	N/A	220 - 6000
Hot-dip galvanized sheets	Thickness	0,4 - 4	0,4 - 4	0,4 - 4
	Width	400 - 1650	30 - 1650	200 - 1650
	Length	N/A	N/A	220 - 6000
Electrolytically Galvanized Sheets	Thickness	0,4 - 3	0,4 - 3	0,4 - 3
	Width	400 - 1650	30 - 1650	200 - 1650
	Length	N/A	N/A	220 - 6000
AUTOMOTIVE Sheets	Thickness	0,4 - 4	0,4 - 4	0,4 - 4
	Width	400 - 1650	30 - 1650	200 - 1650
	Length	N/A	N/A	220 - 6000



Other sheet and format dimensions and sheet thicknesses are available upon request.



We offer perforation of flat sheets. Details (shape, size, hole pattern, etc.) are agreed individually with the sales department. **For more information, see page 168.**

# Cutting and recoiling services

## Coils rewinding

Before cutting, the sheet can be covered with a protective film or an anti-condensation coating.

Base parameters	
Maximum coil weight	25 t
Maximum strip width	1650 mm
Sheet thickness	0,4-4,0 mm



## Formats - cross-cutting / trapezoid/rhombus

Cross-cutting into sheets and formats according to individual requirements.

Technical specifications*	
Sheet thickness	0,4-4,0 mm
Minimum sheet size	200×220 mm
Maximum sheet size	1650×6000 mm
Shape	Trapezoid/rhombus 35° +/- 1°
Dimensional tolerance	+/- 0,2 mm / 1 mm
Flatness of sheet	According to EN standards or individual arrangements

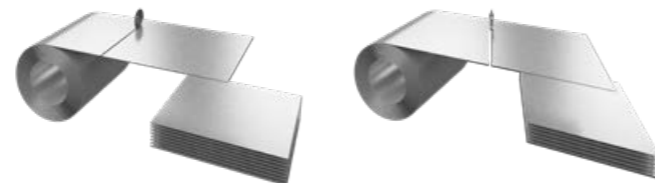

Examples of format shapes



## Slitting - longitudinal cutting

Slitting to strip according to individual requirements.

Technical specifications*	
Sheet thickness	0,4-4,0 mm
Loading width	400-1650 mm
Maximum coil weight	25 t
Cutting width ranges	30-1650 mm
Width tolerance of cut strip	+/- 0,2 mm
Internal diameter of cut strip	508-610 mm



\* The data shown are for the feedstock offered by BP2. Consultation with the sales department is required to determine the parameters for the material to be supplied. When recoiling and slitting without interfering in the width of the charge, metallurgical tolerances according to standards apply:

- dimensional and shape tolerances: EN 10143,
- metallic coatings and surface quality: EN 10326, EN 10327,
- organic coatings and surface quality: EN 10169.

# Protective films

## Protection - types of film

In order to protect the sheet metal on request, it is coated with a protective film. As a standard, we use a film of an individually selected composition as a result of tests for the respective sheet metal coating: the type and thickness of the adhesive layer and the film were determined in such a way as to ensure adequate adhesion and not to damage the coating during removal. We offer films with various parameters which can be individually selected, taking into account:



### Adhesives

- acrylic, water - ecological, water washable,
- acrylic, solvent - not soluble in water, used for matt coatings
- rubber, solvent - not soluble in water, used for polyester coatings.



### Light transmission

- opaque and transparent films.

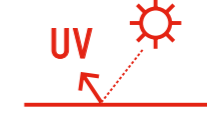

### UV resistance

- from 1 to 12 months.



### Condensation of water vapour

- anti-condensation coating.

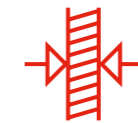

### Film thickness

- 35-100µm.

### Foil type

- MAT/GLOSS.

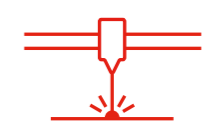

### Application

- universal films, dedicated to the type of coating and special applications, such as laser cutting (Fiber).

## VCI film with LDPE inhibitor

Flat sheets can be protected with VCI film with LDPE inhibitor. This is an anti-corrosion film dedicated to protecting materials exposed to corrosion or moisture during transport and storage. The film's durability is:







- antistatic properties: 9 months
- VCI inhibitor: 12 months provided that storage conditions are observed.

# Perforation of sheets

Perforated sheets are widely used to achieve the desired stylistic effect in external and internal architecture. Sheet perforation is ideal for ventilated curtain walling systems or used to illuminate the façade from the inside. Perforated sheets are used for furniture elements or household appliances. Perforation also provides soundproofing and sound absorption for production and industrial facilities.

We offer perforation of metal and organic coated sheets from our regular offer\* Perforated sheets can be re-profiled by us to make sheet metal coverings and structural elements, such as trapezoidal and corrugated sheets, wall cassettes, SKRIN cladding cassettes, LINEA cladding panels.

**We make perforations in a wide range of sizes and shapes:**

-  — round,
-  — oblong (so called beans),
-  — rectangular,
-  — hexagonal,
-  — stars,
-  — irregular.

**Technical parameters**

Maximum strip width	1500 mm
Sheet thickness	0,4-2,0 mm



\*Additionally, we offer perforation of entrusted material. Details are agreed individually with the sales department.

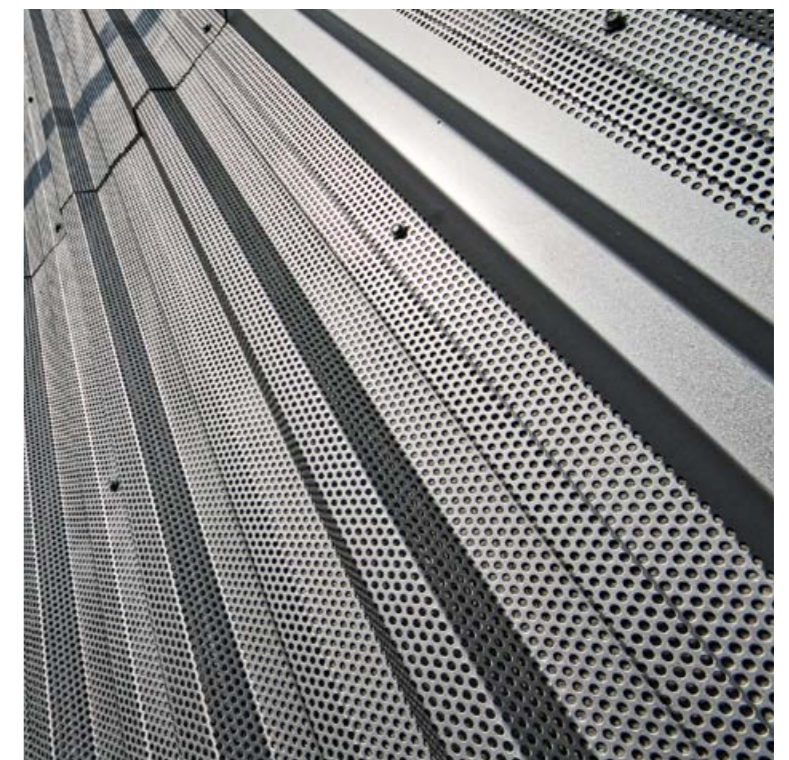
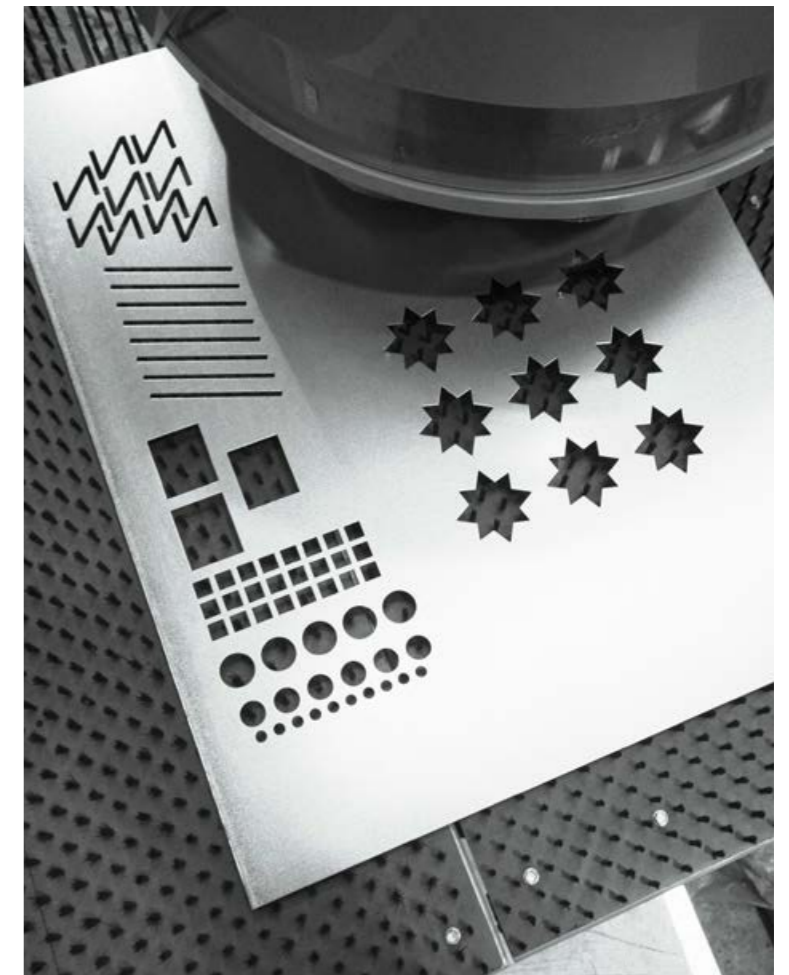
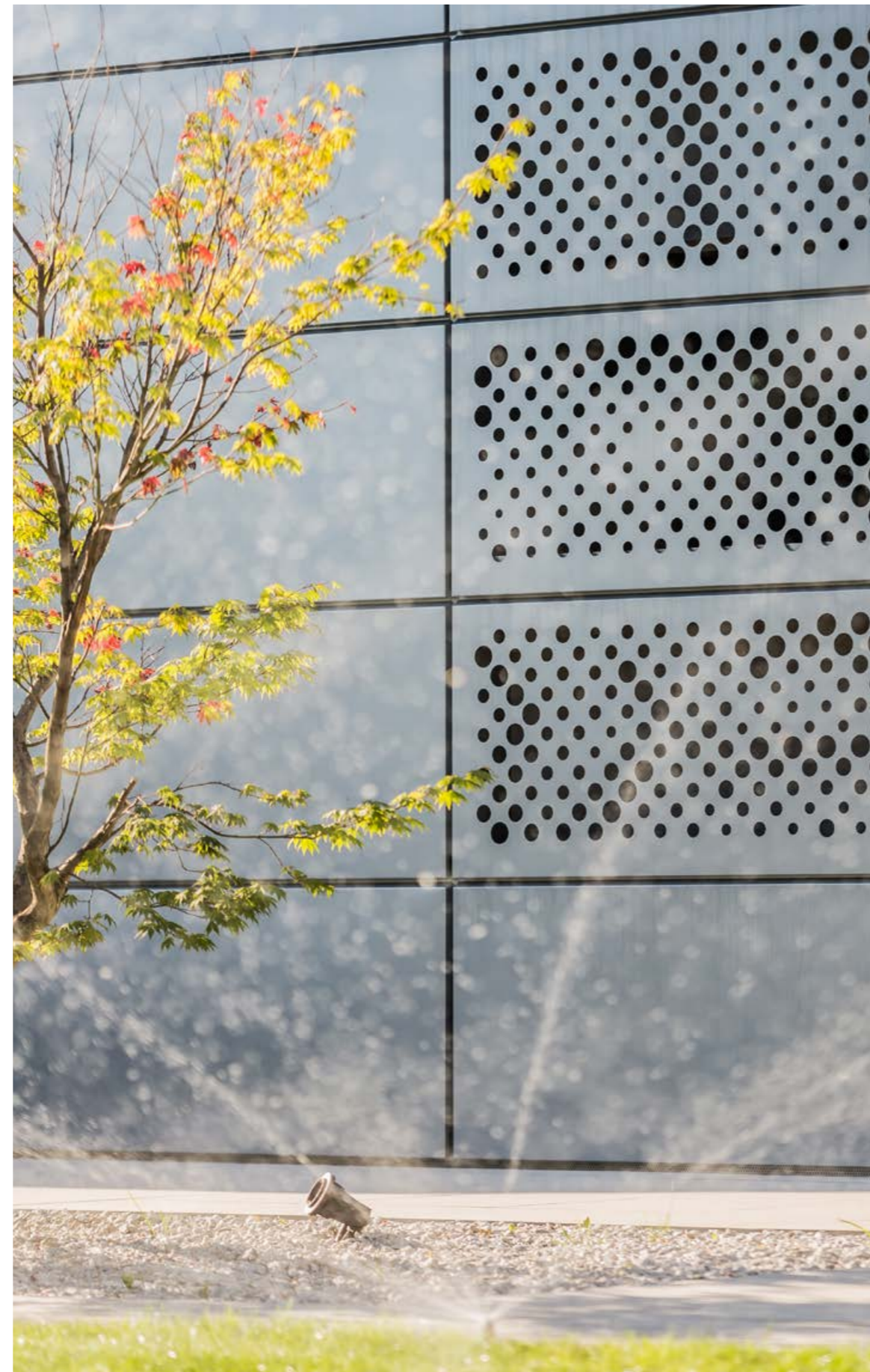



# 15.

## **Technical information**

172. ALUZINC and ZINC coatings

173. Coated sheets

174. Coating descriptions

176. Coating properties

177. Coating availability

178. Anti-condensation coating

180. Colours

# ALUZINC and ZINC coatings

## ZINC [ZN]

The sheets are hot dip galvanised on both sides in a continuous process which protects the steel core against corrosion. They feature a smooth and uniform surface that meets the highest aesthetic requirements.

## ALUZINC [AZ]

It is a steel sheet coated on both sides with an aluminium-zinc alloy in a process similar to hot-dip galvanising. It thus meets the most stringent requirements for sheet metal resistance to atmospheric corrosion and corrosion in humid environments. It additionally has a protective Easyfilm polymer coating which also protects the edges of the steel coils and enhances the aesthetics of the surface. The warranty period for this type of sheet metal is 25 years.

Sheet section

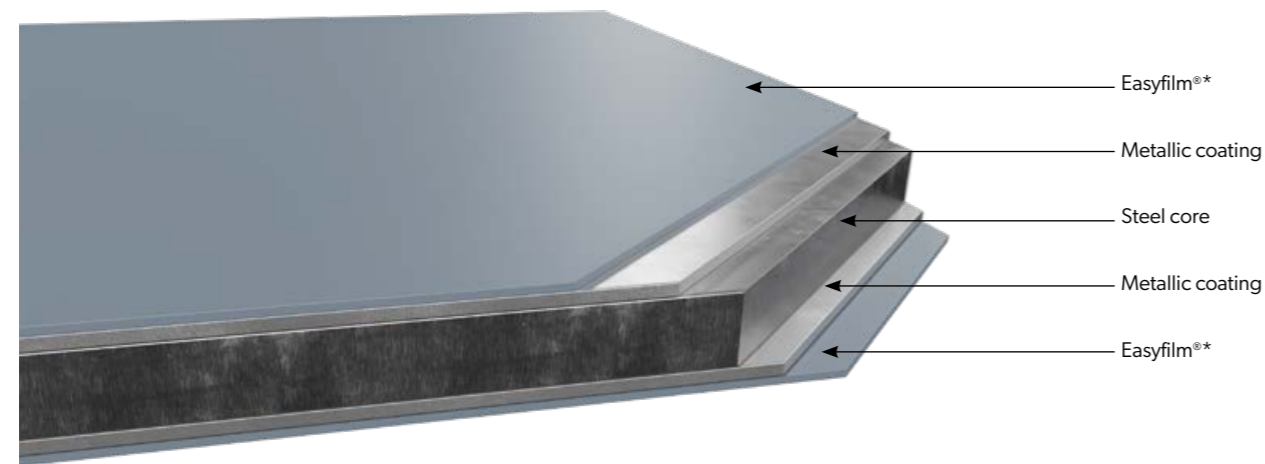

\* only Aluzinc.

# Coated sheets

## COATED SHEETS [HC, UTK, ICep, INT, RAL]

Coated sheets are manufactured from hot-dip galvanised charge or coated with a dedicated alloy (zinc, magnesium zinc, aluminium zinc). This material, cleaned during pretreatment, undergoes passivation processes and is then multi-coated with one of the many available coatings. This provides excellent protection of the metallic layers and the steel core against atmospheric agents. Coatings can vary in thickness, colour, and surface texture. Their warranty period is 55 years.



Detailed warranty conditions are specified in the warranty card. For MODULAR SERIES modular roof tiles and COMPACT SERIES compact roof tiles the warranty becomes valid after registration on the website [www.warranty.bp2.eu](http://www.warranty.bp2.eu).

Coated sheet cross-section

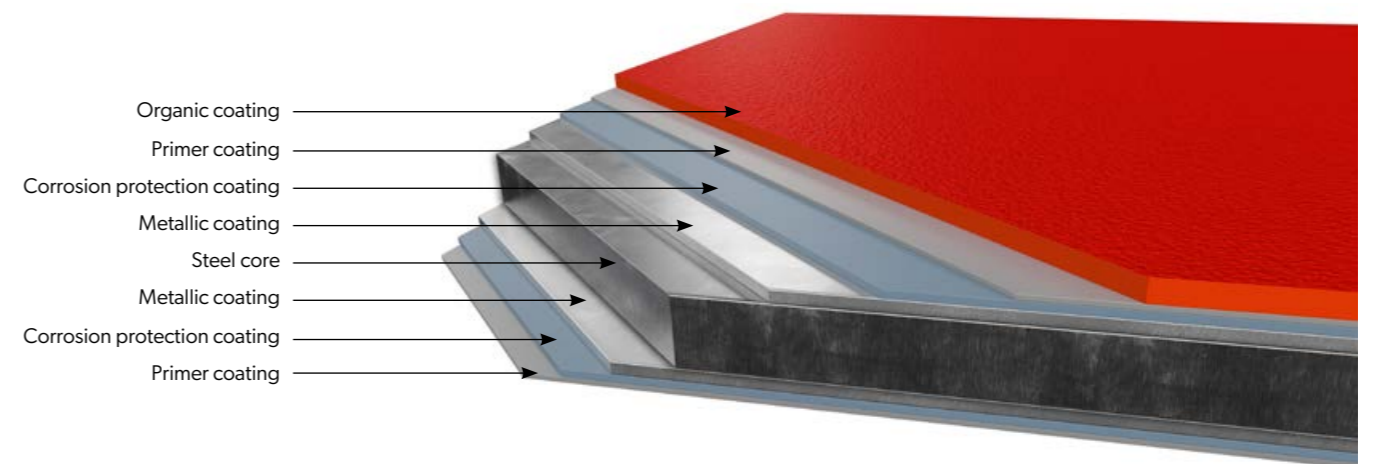

# Coating descriptions

## HERCULIT [HC]

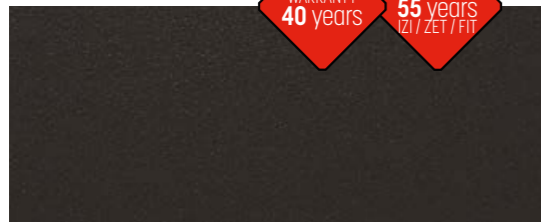

It is a coating developed in close cooperation with a leading manufacturer of varnishes for the best steel mills in Europe. Many years of studying existing coatings and monitoring customer needs, with particular emphasis on the needs of roofers, have allowed us to condense so many different advantages into one product. HERCULIT is a polyurethane-cured polyester with a high resistance to mechanical damage and a thickness of 35 µm.

HERCULIT offers a 40-year warranty and reproducibility of colours and coating structures. Warranty period for FIT, IZI and ZET - 55 years.

## ICE COVER ZM [ICep]

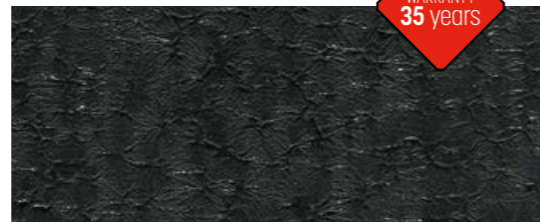

Thick (35 µm) organic coating with an interesting crystalline texture, resembling thickly applied paint. The core is zinc-magnesium alloy coated steel that provides enhanced protection against corrosion. The result is a significant increase in resistance to white and red corrosion in RC3 environments.

Warranty period: 35 years.



Detailed warranty conditions are specified in the warranty card. For MODULAR SERIES modular roof tiles and COMPACT SERIES compact roof tiles the warranty becomes valid after registration on the website [www.warranty.bp2.eu](http://www.warranty.bp2.eu)

## SP35 Multilayer [SP35/MULTI]



40 µm thick polyester paint with Z275 zinc layer or ZM120 zinc-magnesium layer. It is characterised by its wood structure and adequate protection against corrosion and UV radiation. This combination allows outdoor use, especially where high weather resistance and high aesthetics are required.

## POLIESTER Interior [INT]



Sheet metal coated with a 15 µm polyester layer with a smooth and glossy surface. Due to the low thickness of the organic coating, it is mainly intended for interior applications and building elements not directly exposed to weathering.

## ULTIMAT [UTK]



A 35 µm thick coating with very high corrosion and UV resistance (RC4/RUV4). The ULTIMAT coating with its grained structure, inspired by nature, is free of chromium and heavy metals and is a green, recyclable product. Sheet metal coated with the ULTIMAT elastic coating can be profiled at extremely low temperatures.

Warranty period: 20 years.  
Warranty period MODULAR SERIES: 30 years.  
Warranty period extended to 30 years for COMPACT SERIES kits in ULTIMAT [UTK] coating purchased together with the INGURI rainwater system.

## POLIESTER Standard [RAL]

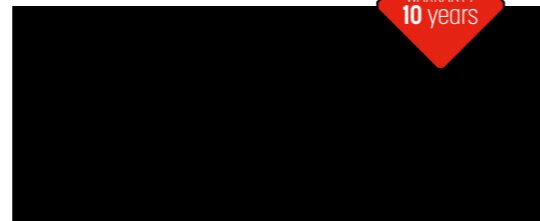

Basic organic coating with a thickness of 25 µm. The surface is uniform, smooth - shiny or metallic. A material with a very wide range of applications. It is available in a wide range of colours described by means of a universal RAL chart.

Warranty period: 10 years.

## CHALKBOARD [C]



The coating for all types of wet-erase boards is manufactured on the basis of a galvanised charge and coated with a Chalkboard paint, making it possible to write on it with chalk. It has additional foil protection.

## MARKERBOARD [M]



The coating for all types of dry erase boards is manufactured on the basis of a galvanised charge and coated with a special Markerboard paint. Surface with gloss of 80-90 GU and hardness of 2H. It is protected by a protective film.



# Coating properties

The following overview is indicative.

Code	Coatings thickness	Corrosion resistance	UV resistance	Warranty period (years)
Zinc [ZN]	200 g/m <sup>2</sup> 275 g/m <sup>2</sup>	RC2	n/a	n/a
Aluzinc [AZ 150]	150 g/m <sup>2</sup>	RC2	n/a	n/a
POLIESTER Interior [INT]	15 µm	RA2	n/a	n/a
POLIESTER Standard [RAL]	25 µm	RC3	RUV2	10
MULTILAYER 40 [MLT]	40 µm	RC3	RUV3	10
ULTIMAT 35 Standard [UTK]	35 µm	RC4	RUV4	20, 30**
Aluzinc [AZ 185]	185 g/m <sup>2</sup>	RC3	n/a	25
ICE COVER ZM [ICep]	35 µm	RC3	RUV4	35
HERCULIT [HC]	35 µm	RC4	RUV4	40 [IZI, ZET, FIT - 55*]

\*Applies to IZI and ZET modular tiles, and FIT roof panel.

\*\*Applies to MODULAR SERIES and COMPACT SERIES with ULTIMAT [UTK] coating purchased together with the INGURI rainwater system.



Detailed warranty conditions are specified in the warranty card. For MODULAR SERIES modular roof tiles and COMPACT SERIES compact roof tiles, the warranty becomes valid after registration on the website [www.warranty.bp2.eu](http://www.warranty.bp2.eu)

# Coating availability

The following overview is indicative.

Code	ZN	AZ 150	INT	RAL	AZ 185	UTK	HC	ICep
Coatings thickness	200/275 g/m <sup>2</sup>	150 g/m <sup>2</sup>	15 µm	25 µm	185g/m <sup>2</sup>	35 µm	35 µm	35 µm
MODULAR SERIES	☐	☐	☐	☐	☐	■	■	☐
COMPACT SERIES	☐	☐	☐	■	☐	■	■	■
CLASSIC SERIES	☐	☐	☐	■	☐	■	■	■
LAMBDA 2.0	☐	■	☐	■	■	■	■	■
Trapezoidal sheets T7 to T18 / T18 ECO	■	■	■	■	■	■	■	■
Trapezoidal sheets T35 to T55	■	■	■	■	■	■	■	■
Trapezoidal sheets T60	■	■	■	■	■	☐	☐	☐
Trapezoidal sheets T80 to T200	☐	☐	■	☐	☐	☐	☐	☐



The possibility of manufacturing profiles with other coatings is discussed individually with the sales department.

# Anti-condensation coating

## DRIPSTOP anti-condensation coating

Condensation is a phenomenon that occurs on uninsulated steel roofing materials. This phenomenon can lead to certain problems, e.g. corrosion, dampness in the attic, and damage to the materials below. BP2.eu offers a simple and economical, yet effective solution to the problem of condensate, which is the application of DRIPSTOP anti-condensation coating.

DRIPSTOP is a self-adhesive membrane bonded to the underside of the sheet. The main advantages of using this technology are:

- absorption of moisture appearing on the inside of the roof as a result of condensation,
- additional protection against corrosive processes (especially in buildings with an active chemical environment, such as stables),
- strength higher than standard insulation and vapour barriers, does not degrade, resistance to tearing,
- easy to clean with standard equipment (hose or pressure washer),
- increase in the degree of acoustic insulation of the covering,
- non-flammability, resistance to bacteria. An anti-condensation coating is applied to the flat metal strip before corrugation. This ensures perfect adhesion over the entire roofing surface.

## Application

The DRIPSTOP anti-condensation coating is used in all types of uninsulated buildings with metal roofing. These include industrial buildings, sports facilities, outbuildings, and all kinds of sheds and shelters.

DRIPSTOP coated sheets can be used to make any profile of tile or trapezoidal sheet from our range. For roof panels mounted on battens, we recommend using a SOUNDCONTROL coating.

## SOUNDCONTROL sound-absorbing coating

The use of SOUNDCONTROL sound-absorbing coating on steel roofing and façade coverings effectively increases their sound insulation level. As a result, both precipitation noise and internal sound propagation are reduced. Coverings with SOUNDCONTROL coating can be used in all types of buildings that require high acoustic standards due to their size or purpose, such as production halls, sports facilities, commercial and residential buildings. Due to the very high moisture absorption capacity of the SOUNDCONTROL coating, it also functions as an anti-condensation membrane. The installation instructions and requirements for ventilation of the building are identical to those for the DRIPSTOP anti-condensation coating described below.



Now the SOUNDCONTROL coating sectional application is also available for the LAMBDA 2.0 product

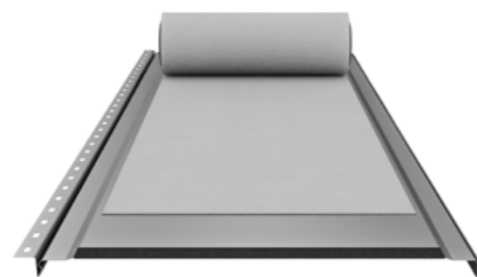

## Installation guidance

When installing the DRIPSTOP anti-condensation coating, it is essential to remove any areas that do not provide an outlet for moist air. This applies in particular to:

1. the parts of the covering directly above the wall and outside the building,
2. the place of overlap of the sheets - if the covering consists of several sheets joined from lengths.

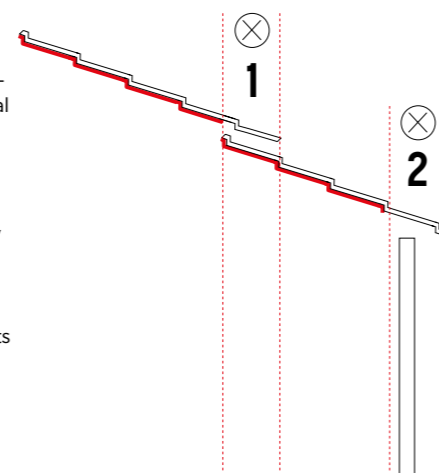

## Properties

The process of condensation begins when atmospheric conditions reach the dew point - a state of temperature and humidity at which water vapour in the atmosphere begins to condense. This usually takes place at sunset. At night, condensation drips off the uninsulated covering. An anti-condensation coating is a membrane with specially designed pockets which, by trapping moisture on one side, prevent it from falling off and insulate the roof covering from direct contact with water on the other. During the day, moisture evaporates from the coating back into the atmosphere.

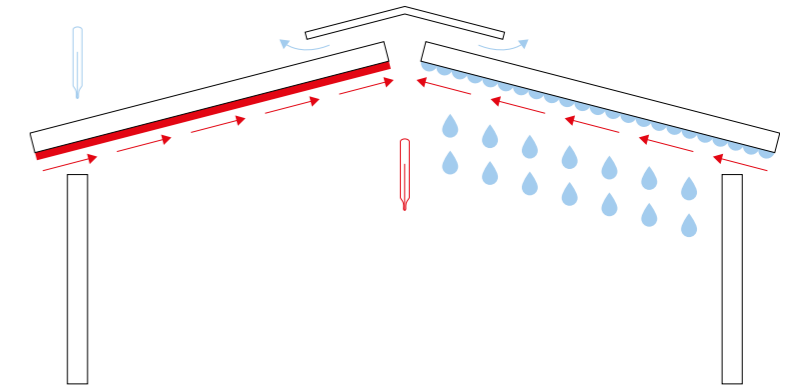

„In the case of buildings, condensation can be enhanced by temperature differences - the inside of the building stays warm while the outside temperature drops quickly. The thermally conductive properties of steel roofing cause strong condensation from the warm room on the inside of the roof.

DRIPSTOP guarantees effective protection of the roofing and underlying materials by stopping the condensation process. Proper ventilation of the building is a prerequisite for the proper functioning of the DRIPSTOP membrane. Because moist air is lighter than dry air, it collects under the roof. In order for the anti-condensation coating to release moisture during the day, an outlet for the moist air is required. This factor should be taken into account when designing the roof. As one of the solutions for ventilating the roof of a building are the indications of DIN 4108-3.”

Evening Passing the dew point causes condensation on the inside of the roofing material.

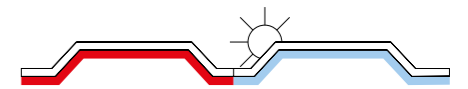

The DRIPSTOP coating absorbs and retains condensation. This prevents water dripping off as in the case of an unprotected covering.

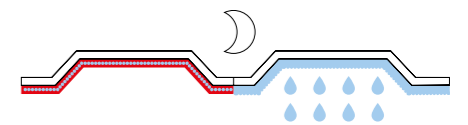

During the day, the anti-condensation coating evaporates moisture.

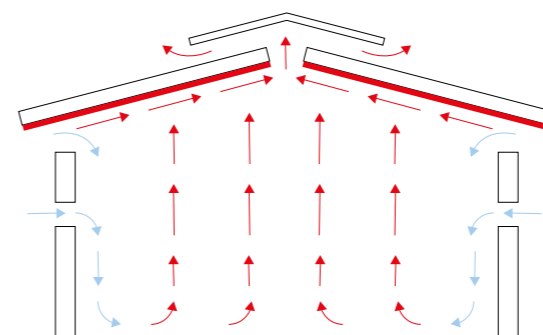

**Proper ventilation**  
The vent provides an outlet for moist air.

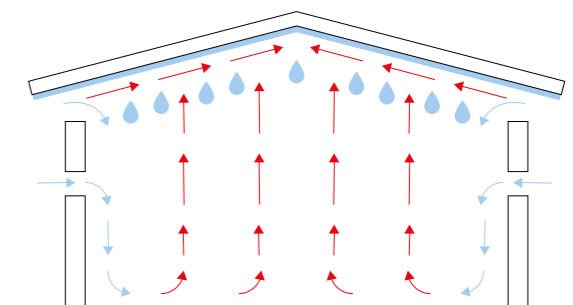

**Incorrect ventilation**  
Moist air is not evacuated.



**ATTENTION!** The bonding is permanent. DRIPSTOP cannot be removed and re-applied. When using DRIPSTOP on the roofing of farm buildings, it is recommended to wash it with a fungicide at least once a year. When installing the covering, the phenomenon of capillary rise should be eliminated. The DRIPSTOP coating must therefore be removed manually in the eaves and ridge area (at least 10 cm spacing). Anti-condensation coated sheets should adhere tightly to the supports and frames of the structure. Therefore, regardless of the profile, they should be fixed to the supports in each lower wave.

# Colours

## HERCULIT [HC]



 The MODULAR SERIES AND COMPACT SERIES roof tiles made of HERCULIT-coated sheets are guaranteed to have a repeatable colour.

## ULTIMAT [UTK]

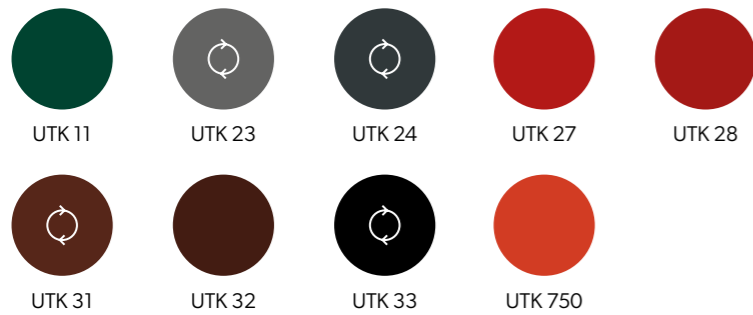

 Sheet colours with the ULTIMAT coating with warranty of repeatability for the MODULAR SERIES roof tiles.

## ICE COVER ZM [ICep]



 In addition, custom colours and coatings are available upon individual request, outside of the palette shown.

 Printing technology does not allow for faithful colour rendition, so the colours shown are approximate and may differ from actual colours.

## POLIESTER Standard [RAL]



## SP35 Multilayer [SP35/MULTI]

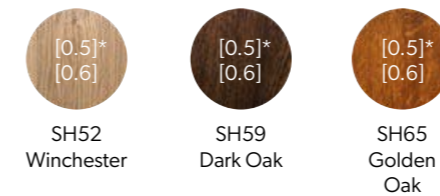

## Metallic coating

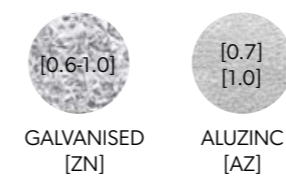

## Board sheets

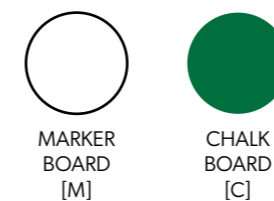

	Standard sheet thickness is 0.5 mm
[0.6]	Material also available in 0.6 mm thickness
[0.7]	Material also available in thickness of 0.7 mm
[0.8]	Material also available in 0.8 mm thickness
[1.0]	Material also available in 1.0 mm thickness



# 16.

**Contact us**

184. Helpful links

186. Contact us

# BP2 - Helpful links

 BP2 website 

 BP2 Academy of Masters 

 Login to Eprofil system 

 Documents - installation manuals 

 Warranty registration 



 SOLROOF website 



 Videos - installation manuals 

 Videos - roof realizations 

 facebook.com/bp2eu 

 instagram.com/bp2\_eu 

 linkedin.com/company/bp2eu 

 youtube.com/@BP2eu 

# Contact us



**BP2 sp. z o.o**  
ul. Marii Konopnickiej 29  
30-302 Kraków

NIP: 6762431701

**www.bp2.eu**

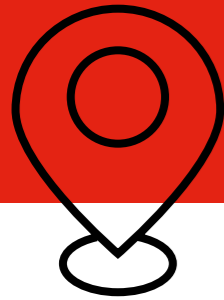

- Distributors
- Sales representatives
- Authorized contractors
- Technical consultancy

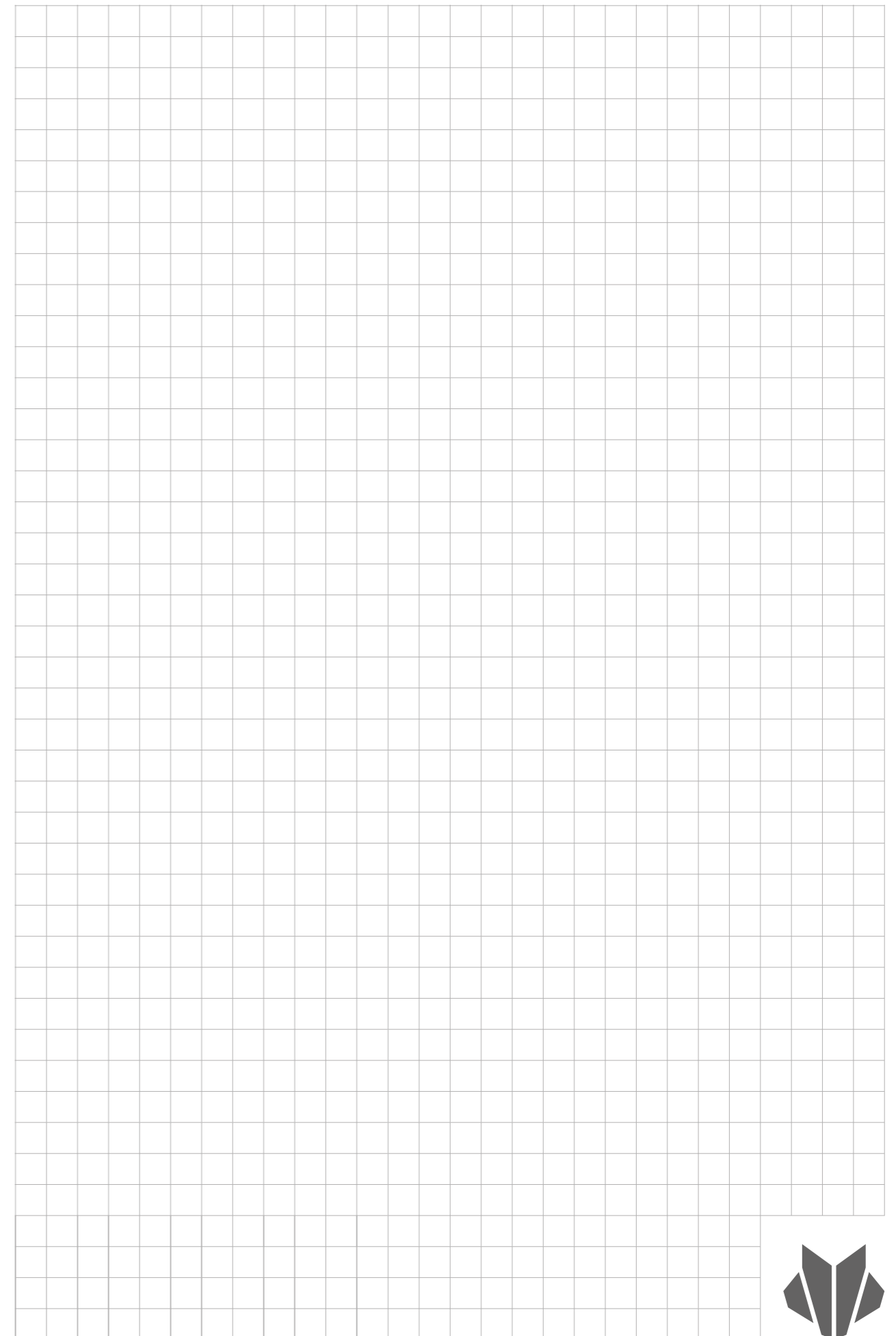

All numerical values and physicochemical characteristics of the products given in the catalogue are indicative and illustrative. The company does not assume any responsibility for any errors or mistakes in editing and printing as well as reserves the right to make changes to product specifications.



This catalogue is an invitation to make an offer as understood by article 14 point 2 of the United Nations Convention on Contracts for the International Sale of Goods.  
Copyright © 2024 BP2. All rights reserved.





Modular roofing tiles  
**MODULAR SERIES**



Compact roofing tiles  
**COMPACT SERIES**



Steel roofing tiles  
**CLASSIC SERIES**



Retro roof tiles  
**RETRO SERIES**



Roof panels  
**PANEL SERIES**



INTEGRATED  
**PV PANELS**



Steel roof gutter system  
**INGURI**



**TRAPEZOIDAL**  
SHEETS



**FLAT METAL**  
SHEETS



**FLASHINGS**



**ACCESORIES**



**Roof Sandwich**  
PANELS



**Wall Sandwich**  
PANELS



Facade cladding  
**SKRIN, LINEA, SINUS**



Wall cassette &  
**PROSYSTEM**



Uncoiling and slitting  
**SERVICES**



Flat sheets and cutting  
**SERVICES**



**PERFORATION**  
of sheets

